

DATA BOOK

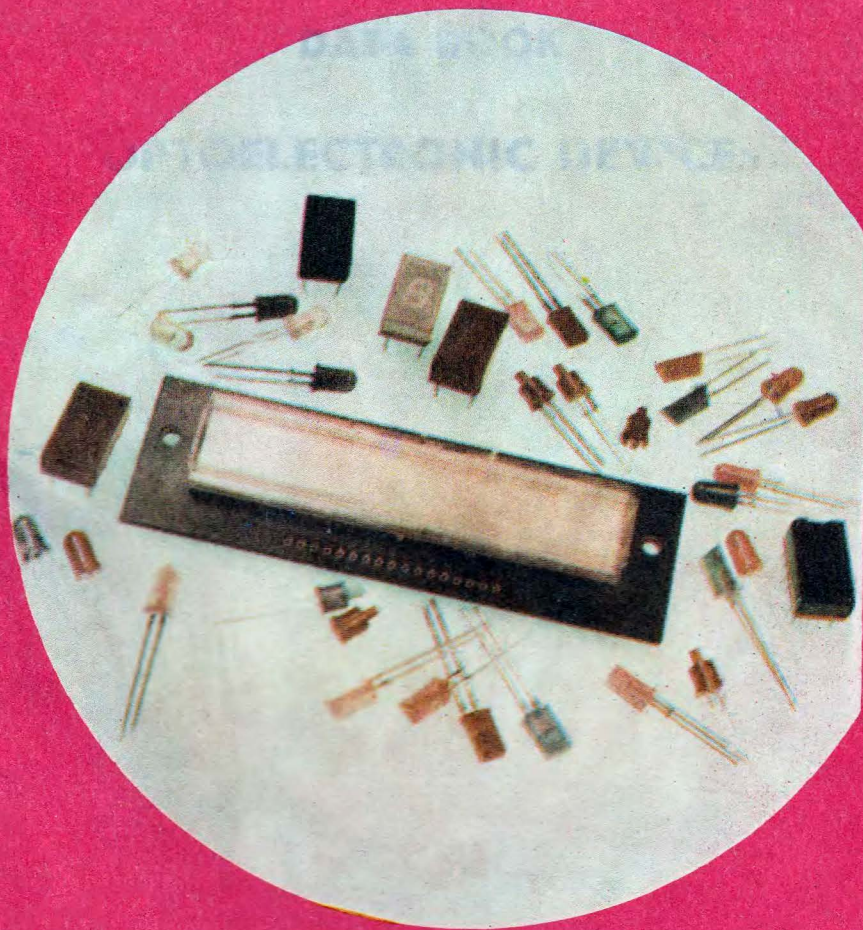

MICROELECTRONICA SA

CONTENT

DATA BOOK

OPTOELECTRONIC DEVICES

Cross Reference Guide

MICROELECTRONICA

346 Eton Lane, Newark, NJ 07102-4350

EDITION 1991

DATA BOOK

OPTOELECTRONIC DEVICES

MICROELECTRONICA

34B Erou Iancu Nicolae 72996 Bucharest
ROMANIA Phone: 334050 / 356, 404.

VORNICU
SANT

CONTENT

- Visible Light Emitting Diodes
- Infrared Light Emitting Diodes
- Phototransistors
- Optocouplers
- Displays
- Cross Reference Guide

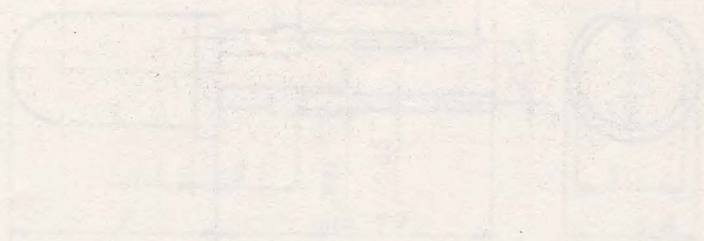

VISIBLE LIGHT EMITTING DIODES

STANDARD LEDs

MDE 1101,2,3 R
MDE 1101,2,3 P
MDE 1101,2,3 G
MDE 1101,2,3 V
MDE 1111,2,3 R

HIGH EFFICIENCY LEDs

MDE 1106,7,8 R
MDE 1106,7,8 P
MDE 1106,7,8 G
MDE 1106,7,8 V
MDE 1116,7,8 R
MDE 1126,7,8 R
MDE 1126,7,8 P
MDE 1126,7,8 G
MDE 1126,7,8 V
MDE 1136,7,8 R
MDE 1146,7,8 R
MDE 1146,7,8 P
MDE 1146,7,8 G
MDE 1146,7,8 V
MDE 1156,7,8 R
MDE 1156,7,8 P
MDE 1156,7,8 G
MDE 1156,7,8 V
MDE 1166,7,8 R

MINIATURE LEDs

MDE 1301,2,3 R
MDE 1301,2,3 P
MDE 1301,2,3 G
MDE 1301,2,3 V

RECTANGULAR LEDs

MDE 1531,2,3 R
MDE 1531,2,3 P
MDE 1531,2,3 G
MDE 1531,2,3 V
MDE 1534,5,6 R

TRIANGULAR LEDs

MDE 1541,2,3 R
MDE 1541,2,3 P
MDE 1541,2,3 G
MDE 1541,2,3 V

FLAT TOP LEDs

MDE 1511,2,3 R
MDE 1511,2,3 P
MDE 1511,2,3 G
MDE 1511,2,3 V

POLARITY INDICATORS

MDE 1141 RV
MDE 1142 RV
MDE 1143 RV

RESISTOR LEDs

MDE 1601 R
MDE 1601 P
MDE 1601 G
MDE 1601 V

STANDARD LIGHT EMITTING DIODES (\varnothing 5 ROUND TYPE)

GENERAL DESCRIPTION

The Standard Light Emitting Diodes are solid state lamps which include a light emitting diode (LED) mounted on a lead-frame and encapsulated in a \varnothing 5 mm standard case of a standard epoxy composition. The short lead is the cathode. The shape and the composition of the case provide a wide viewing angle, uniform aesthetic appearance and an excellent off / on contrast. The MDE Standard Light Emitting Diodes have two red series. The difference between them consists in the semiconductor LED chip type.

The 1101...3 R series has a GaAsP / GaAs or GaAsP / GaP red LED and the 1111...3 R has a GaP / GaP red LED.

These lamps are intended for High Volume / Low cost application such as indicators for appliances, automobil instrument panels and many commercial uses.

FEATURES

- * Low power consumption
- * Long life
- * Low cost
- * Broad application
- * Diffused lens

ABSOLUTE MAXIMUM RATINGS $T_{amb} - 25^{\circ}\text{C}$

	Symbol	Unit.	Value
Power Dissipation	P_{tot}	mW	150
Forward Current	I_F	mA	50
Peak Forward Current (1 μ s pulse width, 300 pps)	I_{FP}	A	1
Operating Temperature	T_{OP}	$^{\circ}\text{C}$	-25...+70
Storage Temperature	T_{stg}	$^{\circ}\text{C}$	-40...+70
Lead Soldering Temperature ($t_{sld} = 3s$)	T_{sld}	$^{\circ}\text{C}$	+260

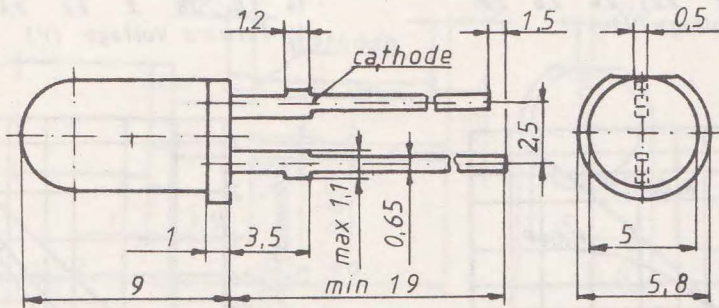

OPTOELECTRIC CHARACTERISTICS AT $T_{amb} = 25^{\circ}\text{C}$

Type	$I_F = 20\text{mA}$				$I_V = 100\mu\text{A}$			
	$V_F(\text{V})$	$I_V(\text{mcd})$	$\lambda_F(\text{nm})$		$\Delta\theta_{0,5}(\text{deg})$		$V_{BK}(\text{V})$	Case
	max.	min.	min.	max.	min.	min.		
MDE 1101R	3	0,3	635	680	40	5	red, diffused	
MDE 1102R		1						
MDE 1103R		2						
MDE 1101P	3	0,3	590	635	40	5	orange, diffused,	
MDE 1102P		1,5						
MDE 1103P		2,5						
MDE 1101G	3	0,3	573	590	40	5	yellow, diffused	
MDE 1102G		1,5						
MDE 1103G		2,5						
MDE 1101V	3	0,3	554	573	40	5	green, diffused	
MDE 1102V		1						
MDE 1103V		2						
MDE 1111R	3	0,3	680	710	40	5	red, diffused	
MDE 1112R		1						
MDE 1113R		2						

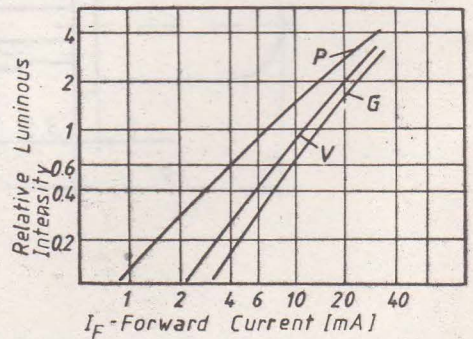
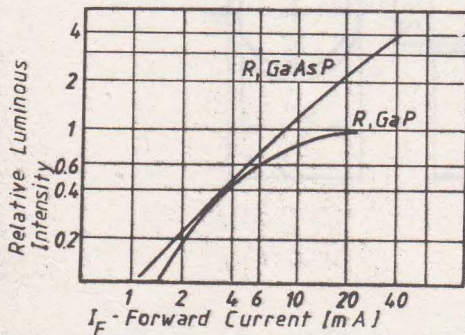
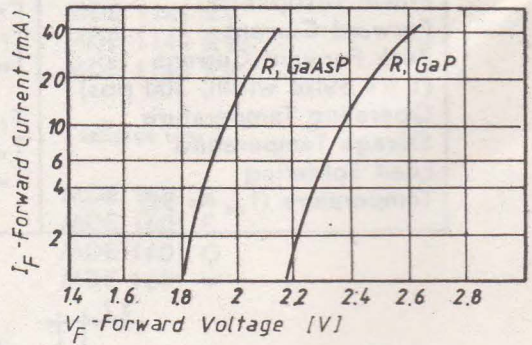
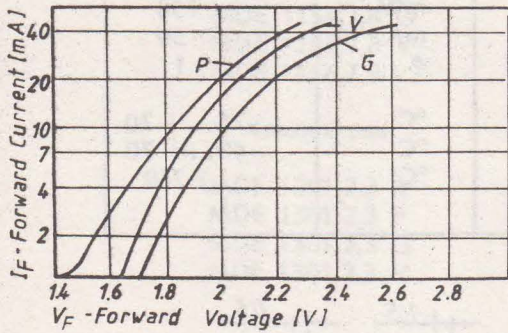

HIGH EFFICIENCY LIGHT EMITTING DIODES

GENERAL DESCRIPTION

These solid state lamps include a red (R), orange (P), yellow (G) or green (V) light emitting diode packed in a $\varnothing 5$ mm epoxy case.

The luminous intensity of these lamps is high and the viewing angle narrow.

The coloured undiffused and the white lens high efficiency light emitting diodes are designed for applications where a point source is desired. They are particularly useful where the light must be focused or diffused with external optics.

The white lens is useful in masking the colour of the lamp in the off condition.

FEATURES

- * High intensity
- * Narrow viewing angle
- * Low power consumption
- * Long life

ABSOLUTE MAXIMUM RATINGS

$T_{amb} = 25^{\circ}\text{C}$

	Symbol	Unit.	Value
Power Dissipation	P_{tot}	mW	150
Forward Current	I_F	mA	50
Peak Forward Current (1 μs pulse width, 300 pps)	I_{FP}	A	1
Operating Temperature	T_{OP}	$^{\circ}\text{C}$	-25...+70
Storage Temperature	T_{stg}	$^{\circ}\text{C}$	-40...+70
Lead Soldering Temperature ($t_{slid} = 3\text{s}$)	T_{slid}	$^{\circ}\text{C}$	+260

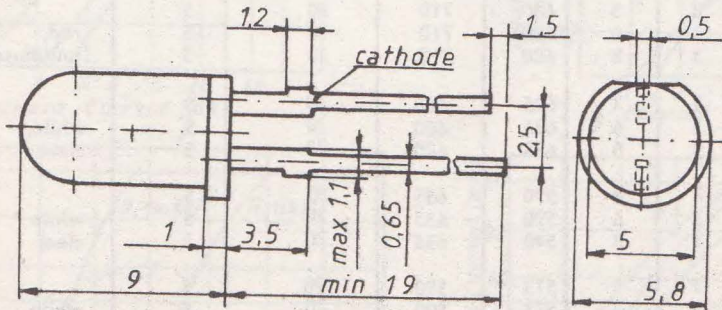

OPTOELECTRIC CHARACTERISTICS AT $T_{amb}=25^{\circ}C$

Type	$I_F=20mA$				$I_R=100\mu A$		Case
	$V_F(V)$	$I_V(mcd)$	$\lambda_p (nm)$		$\Delta\theta_{0,5} (deg)$	$V_{BR}(V)$	
	max.	min.	min.	max.	min.	min.	
MDE 1106R	3	3	635	680	20	5	red, undiffused
MDE 1107R	3	6	635	680	20	5	
MDE 1108R	3	8	635	680	20	5	
MDE 1106P	3	3	590	635	20	5	orange, undiffused
MDE 1107P	3	6	590	635	20	5	
MDE 1108P	3	8	590	635	20	5	
MDE 1106G	3	3	573	590	20	5	yellow, undiffused
MDE 1107G	3	6	573	590	20	5	
MDE 1108G	3	8	573	590	20	5	
MDE 1106V	3	3	554	573	20	5	green, undiffused
MDE 1107V	3	6	554	573	20	5	
MDE 1108V	3	8	554	573	20	5	
MDE 1116R	3	3	680	710	25	5	red, slow, diffused
MDE 1117R	3	6	680	710	25	5	
MDE 1118R	3	8	680	710	25	5	
MDE 1126R	3	3	635	680	25	5	red, slow, diffused
MDE 1127R	3	6	635	680	25	5	
MDE 1128R	3	8	635	680	25	5	
MDE 1126P	3	3	590	635	25	5	orange, slow, diffused
MDE 1127P	3	6	590	635	25	5	
MDE 1128P	3	8	590	635	25	5	
MDE 1126G	3	3	573	590	25	5	yellow, slow, diffused
MDE 1127G	3	6	573	590	25	5	
MDE 1128G	3	8	573	590	25	5	
MDE 1126V	3	3	554	573	25	5	green, slow, diffused
MDE 1127V	3	6	554	573	25	5	
MDE 1128V	3	8	554	573	25	5	
MDE 1136R	3	3	680	710	20	5	red, undiffused
MDE 1137R	3	6	680	710	20	5	
MDE 1138R	3	8	680	710	20	5	
MDE 1146R	3	3	635	680	20	5	white, clear
MDE 1146R	3	6	635	680	20	5	
MDE 1146R	3	8	635	680	20	5	
MDE 1146P	3	3	590	635	20	5	white clear
MDE 1146P	3	6	590	635	20	5	
MDE 1146P	3	8	590	635	20	5	
MDE 1146G	3	3	573	590	20	5	white clear
MDE 1146G	3	6	573	590	20	5	
MDE 1146G	3	8	573	590	20	5	
MDE 1156V	3	3	554	590	20	5	white clear
MDE 1146V	3	6	554	590	20	5	
MDE 1146V	3	8	554	590	20	5	

OPTOELECTRIC CHARACTERISTICS AT $T_{amb}=25^{\circ}C$

Type	$I_F=20mA$				$I_R=100\mu A$		Case
	$V_F(V)$	$I_V(mcd)$	$\lambda_P (nm)$		$\angle H_{0,5} (deg)$	$V_{BR}(V)$	
	max.	min.	min.	max.	min.	min.	
MDE 1156R	3	3	635	680	25	5	white, slow diffused
MDE 1157R	3	6	635	680	25	5	
MDE 1158R	3	8	635	680	25	5	
MDE 1156P	3	3	590	635	25	5	white, slow diffused
MDE 1157P	3	6	590	635	25	5	
MDE 1158P	3	8	590	635	25	5	
MDE 1156G	3	3	573	590	25	5	white, slow diffused
MDE 1157G	3	6	573	590	25	5	
MDE 1158G	3	8	573	590	25	5	
MDE 1156V	3	3	554	573	25	5	white, slow diffused
MDE 1157V	3	6	554	573	25	5	
MDE 1158V	3	8	554	573	25	5	
MDE 1166R	3	3	680	710	25	5	white, slow diffused
MDE 1167R	3	6	680	710	25	5	
MDE 1168R	3	8	680	710	25	5	
MDE 1176R	3	3	680	710	20	5	white, clear
MDE 1177R	3	6	680	710	20	5	
MDE 1178R	3	8	680	710	20	5	

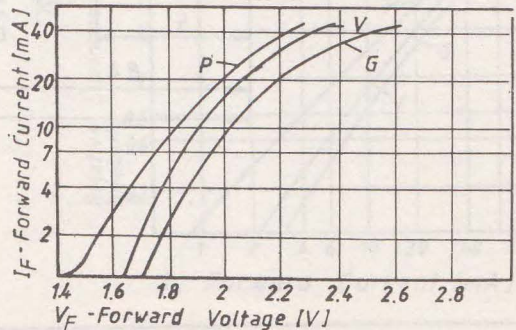
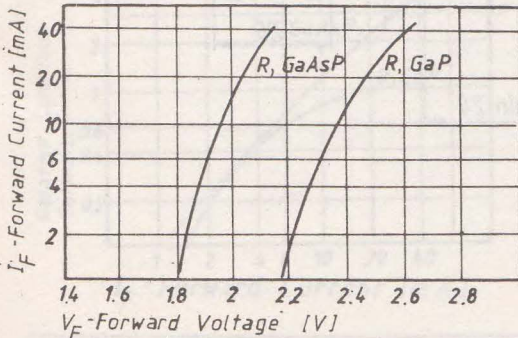
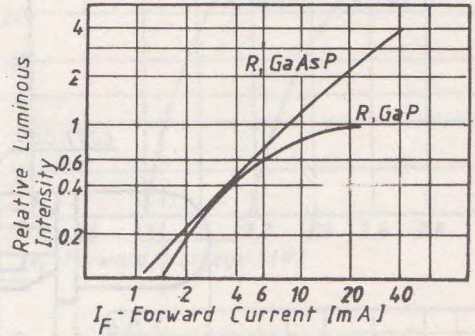
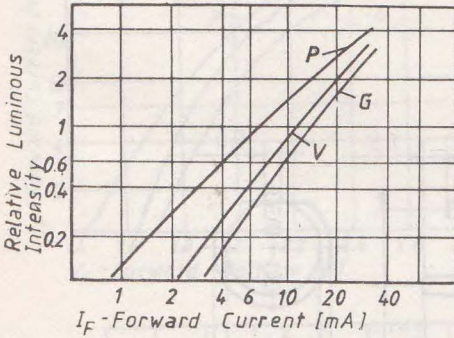

MINIATURE LIGHT EMITTING DIODES

GENERAL DESCRIPTION

The Miniature Light Emitting Diodes are GaAsP or GaP LED chips mounted in a \varnothing 3 mm, diffused coloured epoxy package. Their small size, wide viewing angle and good luminous intensity contribute to their versatility as all purpose indicators.

FEATURES

- * Small size
- * Bright
- * Wide viewing angle
- * Long life
- * Low cost

ABSOLUTE MAXIMUM RATINGS

$T_{amb}=25^{\circ}\text{C}$

	Symbol	Unit.	Value
Power Dissipation	$P_{tot.}$	mW	150
Forward Current	$I_F.$	mA	50
Peak Forward Current (1 μ s pulse width, 300pps)	$I_{FP.}$	A	1
Operating Temperature	$T_{op.}$	$^{\circ}\text{C}$	-25...+70
Storage temperature	$T_{stg.}$	$^{\circ}\text{C}$	-40...+70
Lead Soldering Temperature ($t_{sld}=3s$)	$T_{sld.}$	$^{\circ}\text{C}$	+260

PACKAGE DIMENSIONS

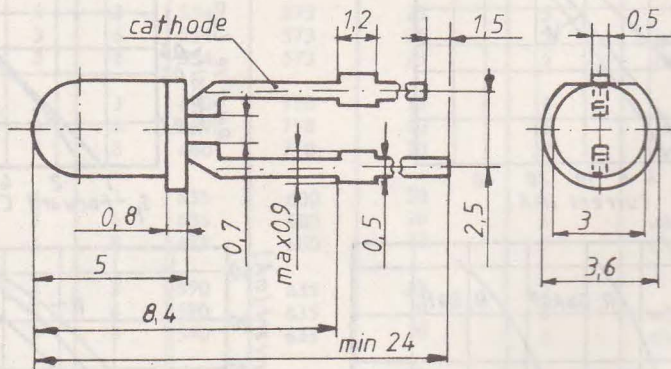

OPTOELECTRIC CHARACTERISTICS AT $T_{amb} = 25^{\circ}C$

Type	$I_F = 20mA$				$I_R = 100\mu A$		Case
	$V_F(V)$	$I_V(mcd)$	λ (nm)		$\theta_{0,5}$ (deg)	$V_{BR}(V)$	
	max.	min.	min.	max.		min.	
MDE 1301R MDE 1302R MDE 1303R	3	0,3 1 2	680	710	40	5	red, diffused
MDE 1301P MDE 1302P MDE 1303P	3	0,3 1,5 2,5	590	635	40	5	orange, diffused
MDE 1301G MDE 1302G MDE 1303G	3	0,3 1,5 2,5	573	590	40	5	yellow, diffused
MDE 1301V MDE 1302V MDE 1303V	3	0,3 1 2	554	570	40	5	green, diffused
MDE 1311R MDE 1312R MDE 1313R	3	0,3 1 2	635	680	40	5	red, diffused

I_F - Forward Current [mA]

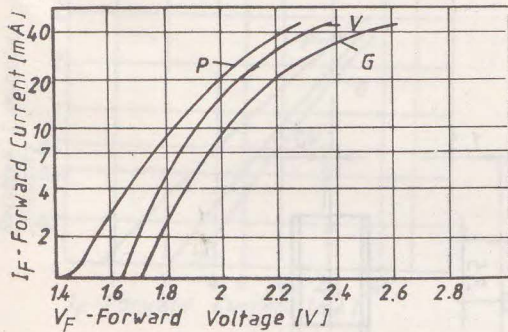

I_F - Forward Current [mA]

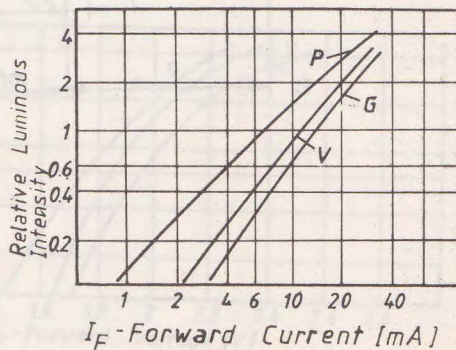
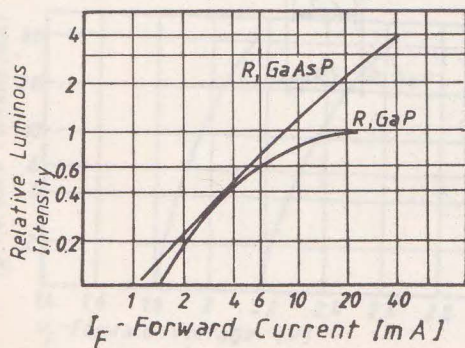
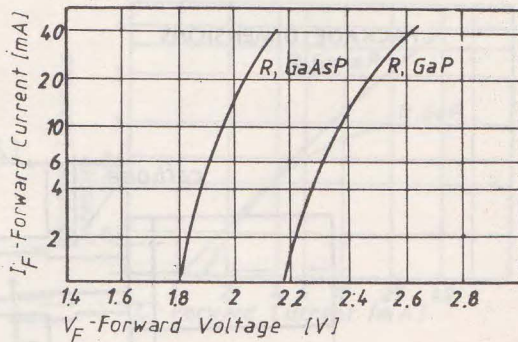

RECTANGULAR LIGHT EMITTING DIODES

GENERAL DESCRIPTION

The MDE 1531...1536 series consists in a red (R) orange (P), yellow (G) or green (V) LED chip mounted on a lead-frame and encapsulated in a top tinted rectangular epoxy package.

FEATURES

- * Rectangular Light Emitting Surface
- * Low current requirements
- * Long life

ABSOLUTE MAXIMUM RATINGS

$T_{amb}=25^{\circ}\text{C}$

	Symbol	Unit.	Value
Power Dissipation	P_{tot}	mW	150
Forward Current	I_F	mA	50
Peak Forward Current (1 μs pulse width, 300pps)	I_{FP}	A	1
Operating Temperature	T_{op}	$^{\circ}\text{C}$	-25...+70
Storage temperature	T_{stg}	$^{\circ}\text{C}$	-40...+70
Lead Soldering Temperature ($t_{sld}=3\text{s}$)	T_{sld}	$^{\circ}\text{C}$	+260

PACKAGE DIMENSIONS

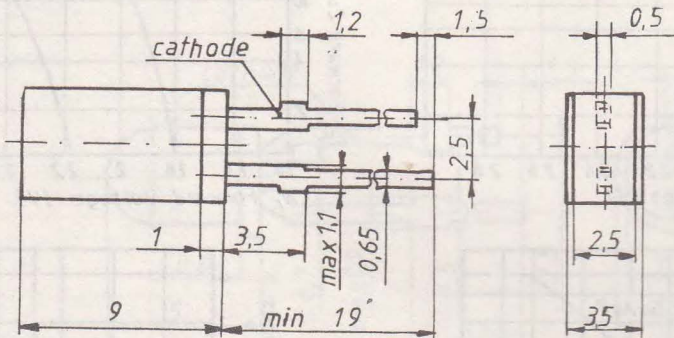

OPTOELECTRIC CHARACTERISTICS AT $T_{amb}=25^{\circ}C$

Type	$I_F=20mA$				$I_R=100\mu A$		Case
	$V_F(V)$	$I_V(mcd)$	$\lambda_p (nm)$		$\Delta\theta_{0,5} (deg)$	$V_{BR}(V)$	
	max.	min.	min.	max.	min.	min.	
MDE 1531R MDE 1532R MDE 1533R	3	0,3 1 2	680 710		50	5	red, diffused
MDE 1531P MDE 1532P MDE 1533P	3	0,3 1,5 2,5	590 635		50	5	orange, diffused
MDE 1531G MDE 1532G MDE 1533G	3	0,3 1,5 2,5	573 590		50	5	yellow, diffused
MDE 1531V MDE 1532V MDE 1533V	3	0,3 1 2	554 570		50	5	green, diffused
MDE 1534R MDE 1535R MDE 1536R	3	0,3 1 2	635 680		50	5	red, diffused

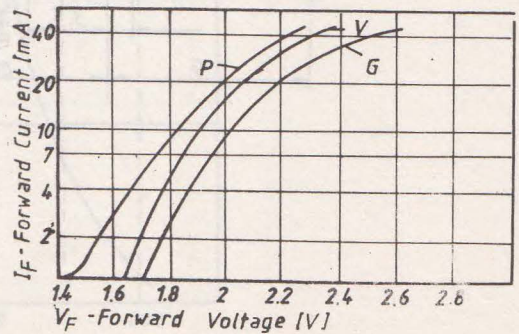
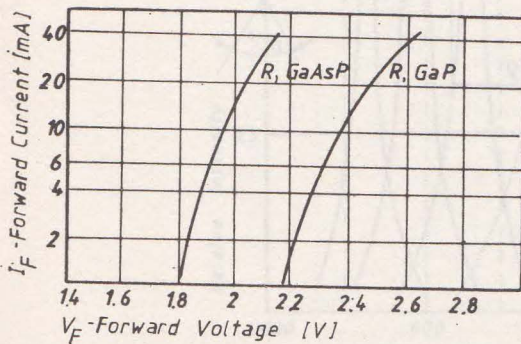
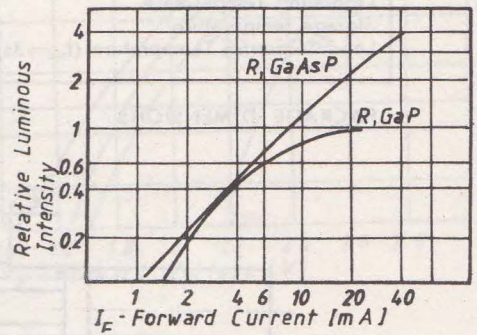
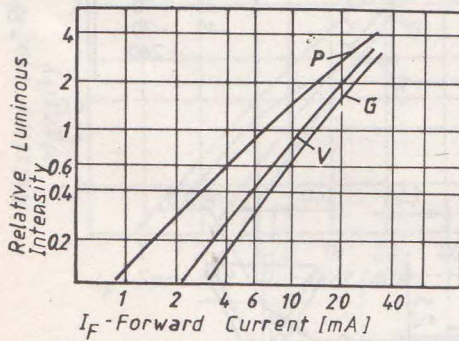

TRIANGULAR LIGHT EMITTING DIODES

GENERAL DESCRIPTION

The MDE 1541...3 series consists in red (R), orange (P), yellow (G) or green (V) LED chips mounted on a lead frame and encapsulated in a top tinted triangular epoxy case.

FEATURES

- * High intensity
- * Triangular Light Emitting Surface
- * Long Life
- * IC Compatible
- * Low Current Requirements

ABSOLUTE MAXIMUM RATINGS

$T_{amb} = 25^{\circ}\text{C}$

	Symbol	Unit.	Value
Power Dissipation	$P_{tot.}$	mW	150
Forward Current	$I_F.$	mA	50
Peak Forward Current (1 μs pulse width, 300pps)	$I_{Fp.}$	A	1
Operating Temperature	$T_{op.}$	$^{\circ}\text{C}$	-25...+70
Storage temperature	$T_{stg.}$	$^{\circ}\text{C}$	-40...+70
Lead Soldering Temperature ($t_{sld}=3\text{s}$)	$T_{sld.}$	$^{\circ}\text{C}$	+260

PACKAGE DIMENSIONS

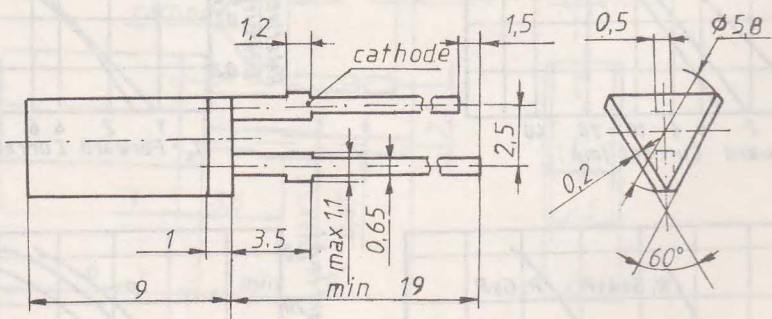

OPTOELECTRIC CHARACTERISTICS AT $T_{amb}=25^{\circ}C$

Type	$I_F=20mA$				$I_R=100\mu A$		Case
	$V_F(V)$	$I_V(mcd)$	$\lambda_P (nm)$		$\Delta\theta_{0,5} (deg)$	$V_{BR}(V)$	
	max.	min.	min.	max.	min.	min.	
MDE 1541R MDE 1542R MDE 1543R	3	0,3 1 2	635	710	50	5	red, diffused
MDE 1541P MDE 1542P MDE 1543P	3	0,3 1,5 2,5	590	635	50	5	orange, diffused
MDE 1541G MDE 1542G MDE 1543G	3	0,3 1,5 2,5	573	590	50	5	yellow, diffused
MDE 1541V MDE 1542V MDE 1543V	3	0,3 1 2	554	573	50	5	green, diffused

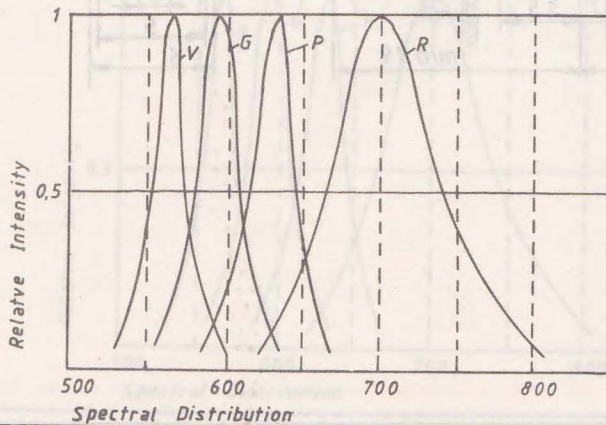
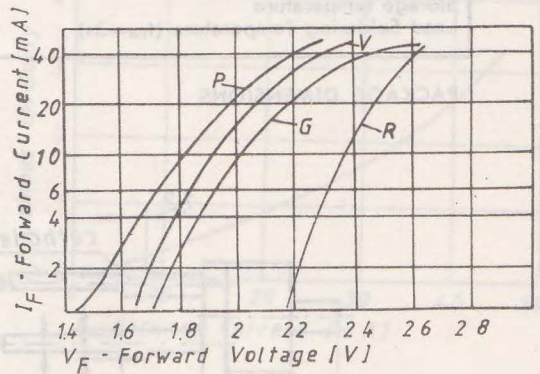
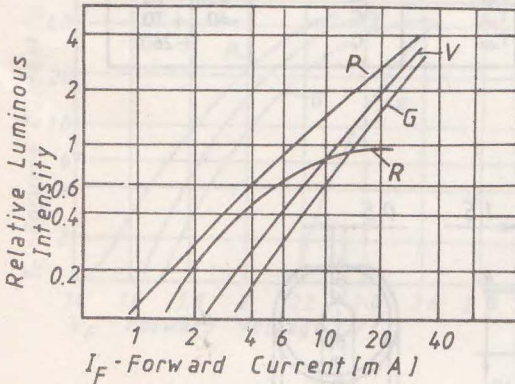

FLAT TOP LEDs (\varnothing 2 mm)

GENERAL DESCRIPTION

The MDE Flat Top LED series has a \varnothing 2 mm, red, yellow, orange or green bright surface. The convex shape of the case permits a good montage on front panels. The length of the pin allows a good penetration through the panel thickness.

FEATURES

- * \varnothing 2 mm uniform illuminated surface
- * Mounts flush with panel
- * Long Life
- * IC Compatible

ABSOLUTE MAXIMUM RATINGS

$T_{amb}=25^{\circ}\text{C}$

	Symbol	Unit.	Value
Power Dissipation	P_{tot}	mW	150
Forward Current	I_F	mA	50
Peak Forward Current (1 μ s pulse width, 300pps)	I_{FP}	A	4
Operating Temperature	T_{op}	$^{\circ}\text{C}$	-25...+70
Storage temperature	T_{stg}	$^{\circ}\text{C}$	-40...+70
Lead Soldering Temperature ($t_{slid}=3s$)	T_{slid}	$^{\circ}\text{C}$	+260

PACKAGE DIMENSIONS

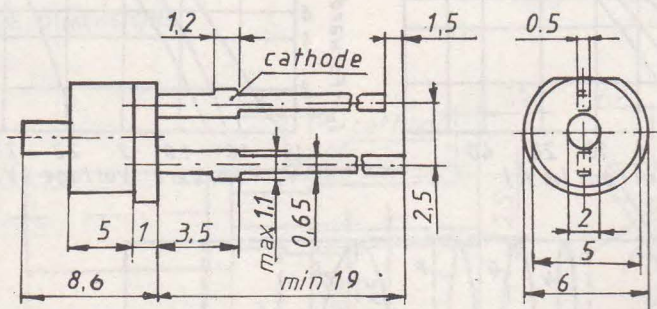

OPTOELECTRIC CHARACTERISTICS AT $T_{amb}=25^{\circ}C$

Type	$I_F=20\text{ mA}$				$I_R=100\mu\text{A}$	
	V_F (V)	I_V (mcd)	λ_p (nm)		V_{BR} (V)	Case
			max.	min.		
MDE 1511R	3	0,4	635	710	5	red, diffused
MDE 1512R		0,6				
MDE 1513R		0,8				
MDE 1511P	3	0,4	590	635	5	orange, diffused
MDE 1512P		0,8				
MDE 1513P		0,5				
MDE 1511G	3	0,4	573	590	5	yellow, diffused
MDE 1512G		0,8				
MDE 1513G		1,5				
MDE 1511V	3	0,4	554	573	5	green, diffused
MDE 1512V		0,6				
MDE 1513V		0,8				

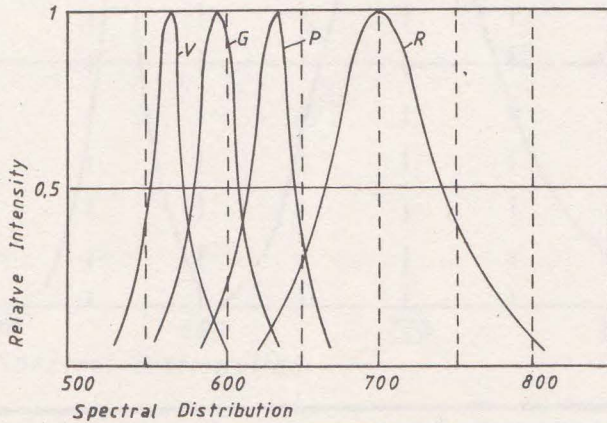
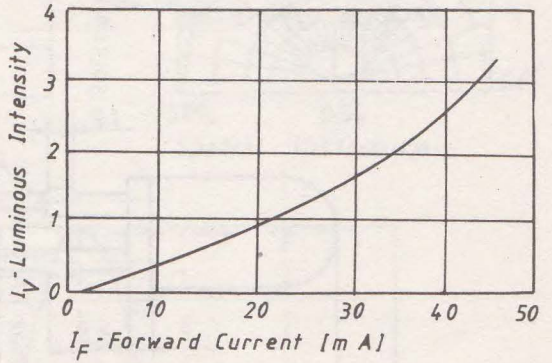
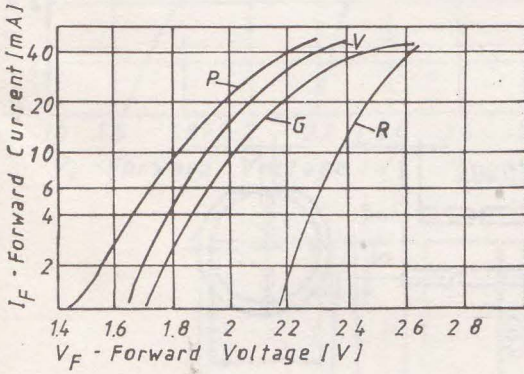

POLARITY INDICATOR LED

GENERAL DESCRIPTION

The MDE Polarity Indicator contains two parallel mounted GaP LED chips: one red and the other green. The Polarity Indicator offers a changing colour dependent on the direction the lamp is biased. This MDE series is white diffused epoxy encapsulated in a standard \varnothing 5 mm case.

FEATURES

- * White epoxy case
- * Wide Viewing Angle
- * High intensity
- * Long life
- * 3 states: red, green, off.

ABSOLUTE MAXIMUM RATINGS

$T_{amb} = 25^{\circ}\text{C}$

	Symbol	Unit.	Value
Power Dissipation	$P_{tot.}$	mW	150
Forward Current	$I_F.$	mA	50
Peak Forward Current (1 μs pulse width, 300pps)	$I_{FP.}$	A	1
Operating Temperature	$T_{op.}$	$^{\circ}\text{C}$	-25...+70
Storage temperature	$T_{stg.}$	$^{\circ}\text{C}$	-40...+70
Lead Soldering Temperature ($t_{sld}=3\text{s}$)	$T_{sld.}$	$^{\circ}\text{C}$	+260

PACKAGE DIMENSIONS

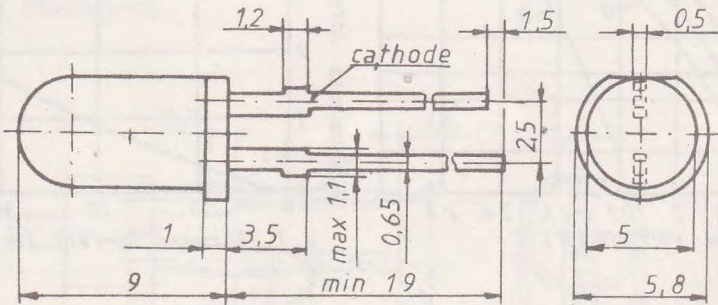

OPTOELECTRIC CHARACTERISTICS AT $T_{amb}=25^{\circ}C$

Type	V (V) max.	I=20mA I _v (mcd) min.	λ_p (nm)	
			R	V
MDE 1141RV	3	0,3	700	560
MDE 1142RV	3	1	700	560
MDE 1143RV	3	2	700	560

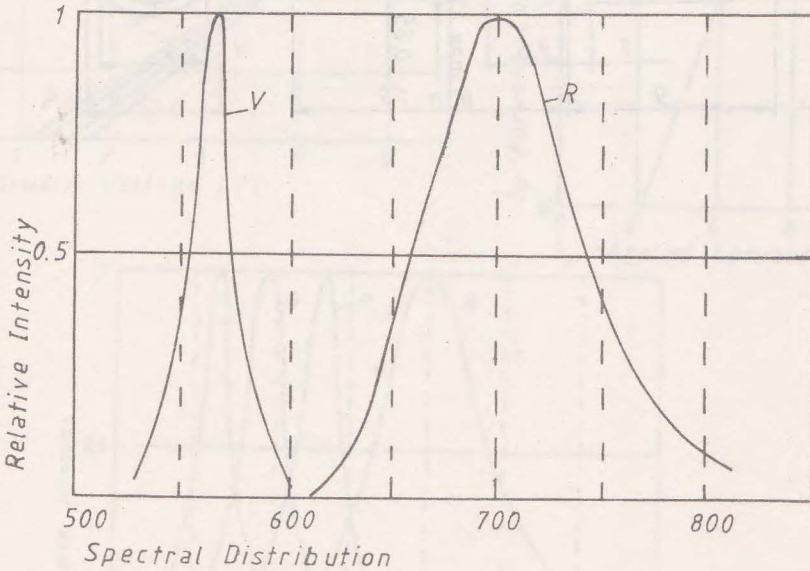
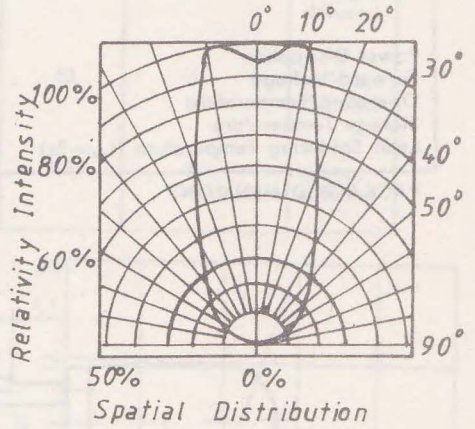
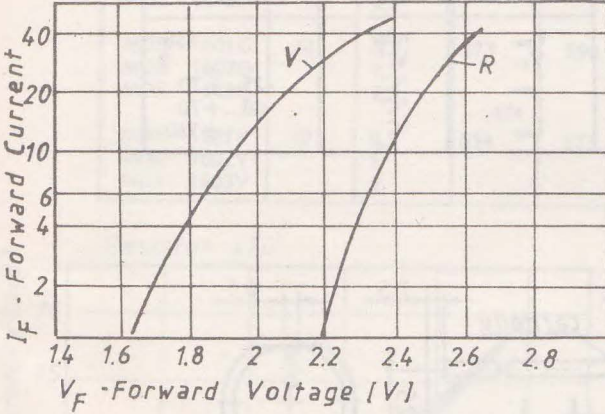

RESISTOR LEDS

GENERAL DESCRIPTION

This solid state resistor lamp contains an integral current limiting resistor in series with the LED. This allows the lamp to be driven from a 5 volts source without the need for an external current limiter.

FEATURES

- * Integral Current Limiting Resistor
- * TTL Compatible
- * Wide viewing angle

ABSOLUTE MAXIMUM RATINGS

$T_{amb} = 25^{\circ}\text{C}$

	Symbol	Unit.	Value
Power Dissipation	$P_{tot.}$	mW	150
Forward Voltage	V_F	V	7
Operating Temperature	$T_{op.}$	$^{\circ}\text{C}$	-25...+70
Storage Temperature	$T_{stg.}$	$^{\circ}\text{C}$	-40...+70
Lead Soldering Temperature ($t_{sld}=3s$)	$T_{sld.}$	$^{\circ}\text{C}$	+260

PACKAGE DIMENSIONS

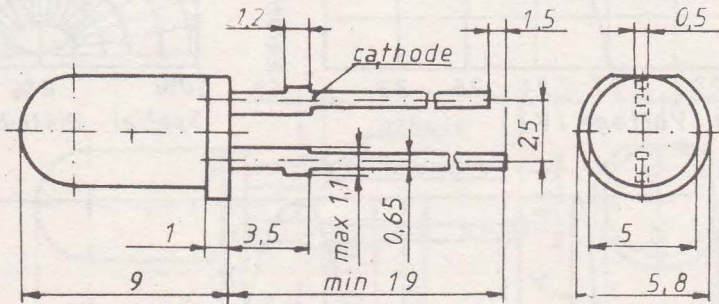

OPTOELECTRIC CHARACTERISTICS AT $T_{amb}=25^{\circ}\text{C}$

Type	$I_F=20\text{ mA}$				$I_R=100\mu\text{A}$		Case
	V_F (V)	I_V (mcd)	λ_P (nm)		$\Delta\theta_{0,5}$ (deg)	V_{BR} (V)	
	max.	min.	min.	max.	min.	min.	
MDE 1601R	20	0,3	615	710	40	5	red, diffused
MDE 1602R		1					
MDE 1603R		2					
MDE 1601P	20	0,3	590	615	40	5	orange, diffused
MDE 1602P		1,5					
MDE 1603P		2,5					
MDE 1601G	20	0,3	573	590	40	5	yellow, diffused
MDE 1602G		1,5					
MDE 1603G		2,5					
MDE 1601V	20	0,3	554	573	40	5	green, diffused
MDE 1602V		1					
MDE 1603V		2					

Resistor LED

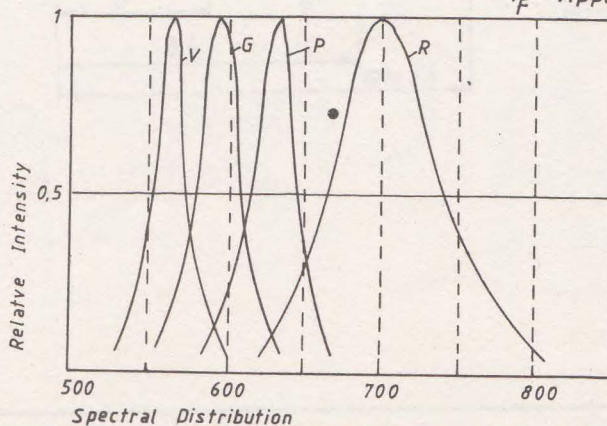
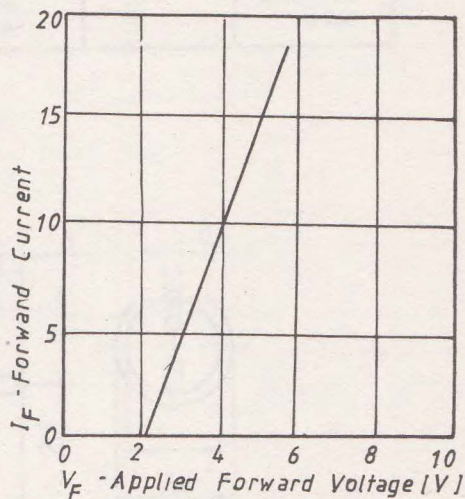
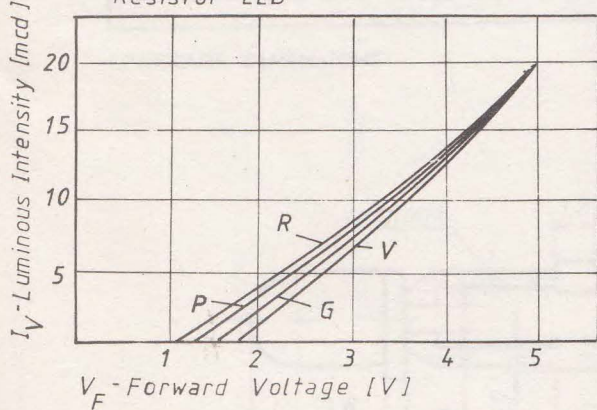

INFREDED LIGHT EMITTING DIODES

MINIATURE IRED

- MDE 3323—12
- MDE 3323—15
- MDE 3323—16

STANDARD IRED

- MDE 3123—12
- MDE 3123—15
- MDE 3123—16
- MDE 3123—02
- MDE 3123—05
- MDE 3123—06

RECTANGULAR IRED

- MDE 3523—11
- MDE 3523—12
- MDE 3523—13

TO—18 HERMETICALLY SEALED IRED

- MDE 3643—12
- MDE 3643—13
- MDE 3643—15

TO—18 PLASTIC LENS IRED

- MDE 3683—11
- MDE 3683—13
- MDE 3683—14

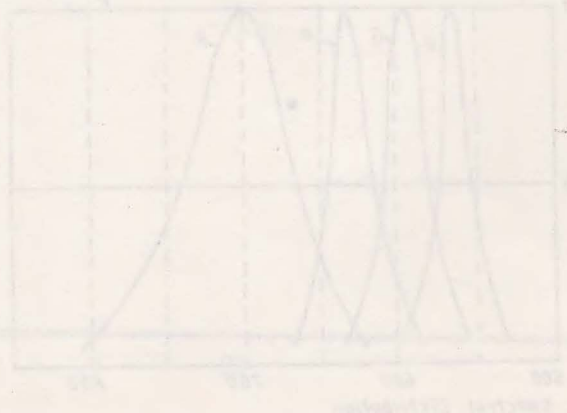
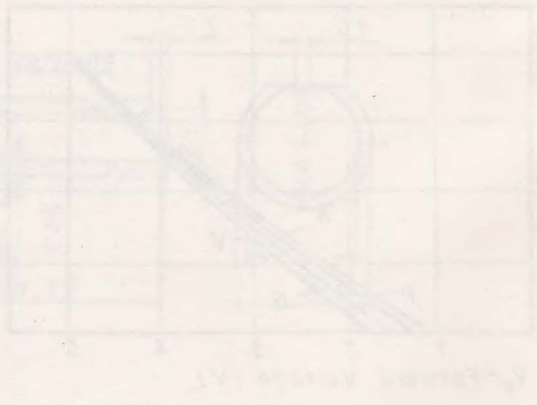

INFRARED LIGHT EMITTING DIODES

The MDE Infrared Light Emitting Diodes are made of efficient liquid epitaxial GaAs LED chips. The MDE 3323 series has a \varnothing 3 mm epoxy case (fig. 1), the MDE 3123 has a \varnothing 5 mm epoxy case (fig. 2) and the MDE 3523 series has a rectangular epoxy case (fig. 3). The MDE 3683 series is mounted on a TO-18 header with epoxy clear lens (fig. 5). The MDE 3643 series with the GaAs infrared LED chip mounted on a TO-18 header had a flat epoxy window cap (fig. 4)

FEATURES

- * Good spectral matching with silicon photodetectors
- * High loading capability in pulse operation
- * High radiant power
- * Vibration resistant
- * Long life

ABSOLUTE MAXIMUM RATINGS

$T_{amb} = 25^{\circ}\text{C}$

	Symbol	Unit.	Value
Power Dissipation	P_{tot}	mW	150
Forward Current	I_F	mA	50
Peak Forward Current (1 μs pulse width, 300pps)	$I_{AZ(\omega)}$	A	1
Operating Temperature	T_{op}	$^{\circ}\text{C}$	-25...+70
Storage temperature	T_{stg}	$^{\circ}\text{C}$	-40...+70
Lead Soldering Temperature ($t_{sld}=3\text{s}$)	T_{sld}	$^{\circ}\text{C}$	+260

PACKAGE DIMENSIONS

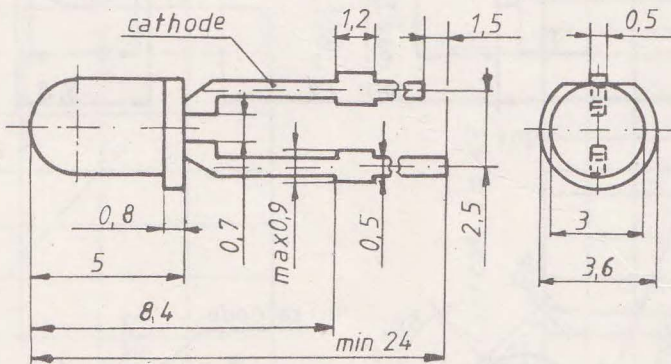

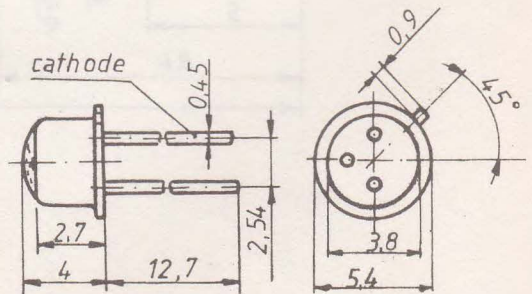
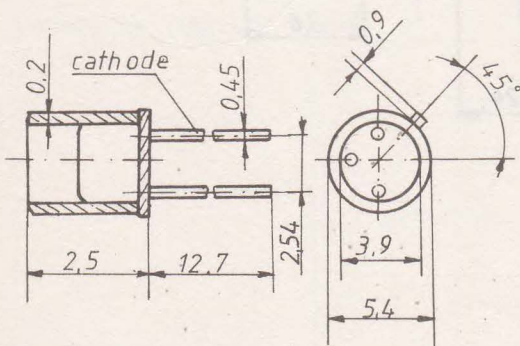
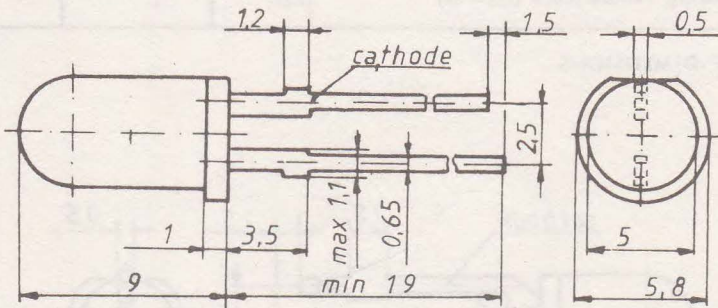
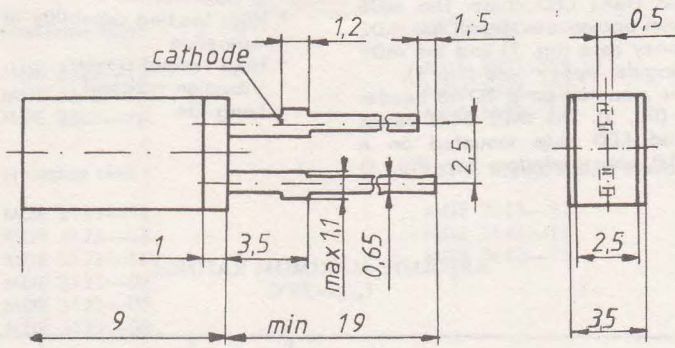

OPTOELECTRIC CHARACTERISTICS AT $T_{amb}=25^{\circ}C$

Type	$I_F=50mA$			$I_R=100\mu A$			Case
	$V_F(V)$	$\lambda_P(nm)$		$\Delta\theta_{0,5} (deg)$	$I_e(mW/sr)$	$V_{BR}(V)$	
	max.	min.	max.		min.	min.	
MDE 3323-12	2	900	980	20	0,5	5	miniature $\varnothing=3mm$ fig.1
MDE 3323-15	2	900	980	20	1	5	
MDE 3323-16	2	900	980	20	2	5	
MDE 3123-12	2	900	980	20	0,5	5	standard $\varnothing=5mm$ fig. 3
MDE 3123-15	2	900	980	20	3	5	
MDE 3123-16	2	900	980	20	5	5	
*MDE 3123-02	2	900	980	20	0,5	5	standard $\varnothing=5mm$ fig. 3
*MDE 3123-05	2	900	980	20	3	5	
*MDE 3123-06	2	900	980	20	5	5	
MDE 3523-11	2	900	980	40	0,1	5	rectangular fig. 2
MDE 3523-12	2	900	980	40	0,5	5	
MDE 3523-13	2	900	980	40	1	5	
**MDE 3643-12	2	900	980	20	0,5	5	TO-18 hermetically sealed fig. 4
**MDE 3643-13	2	900	980	20	1	5	
**MDE 3643-15	2	900	980	20	3	5	
**MDE 3683-11	2	900	980	80	0,2	5	TO-18 plastic lens fig. 5
**MDE 3683-13	2	900	980	80	1	5	
**MDE 3683-14	2	900	980	80	2	5	

NOTES:

* $I_F=100mA$

** Product in development

PACKAGE DIMENSIONS

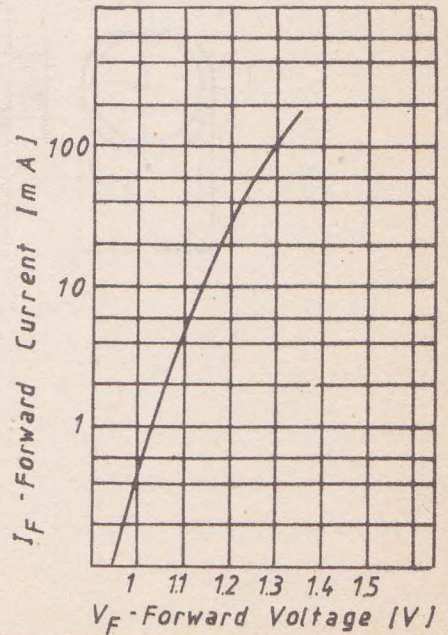
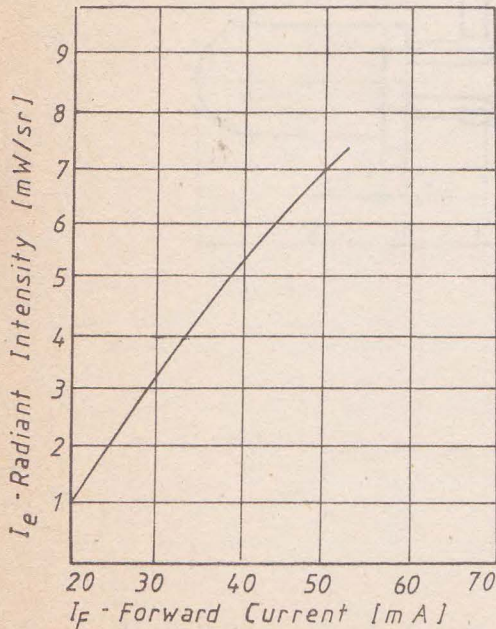

PHOTOTRANSISTORS

STANDARD

- MDR 4213—11A
- MDR 4213—11B
- MDR 4213—11C

RECTANGULAR

- MDR 4213—51A
- MDR 4213—51B

MINIATURE

- MDR 4213—31A
- MDR 4213—31B

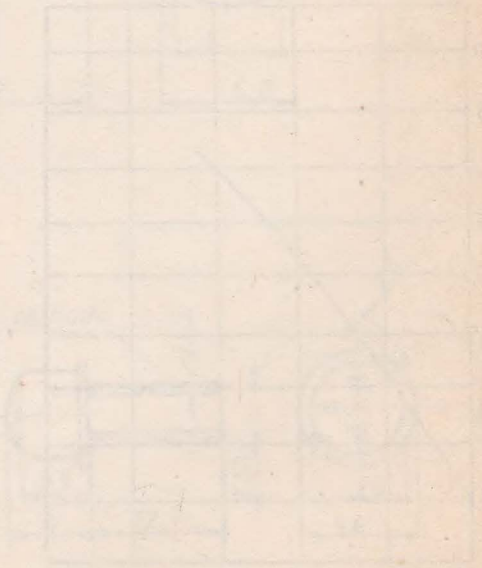
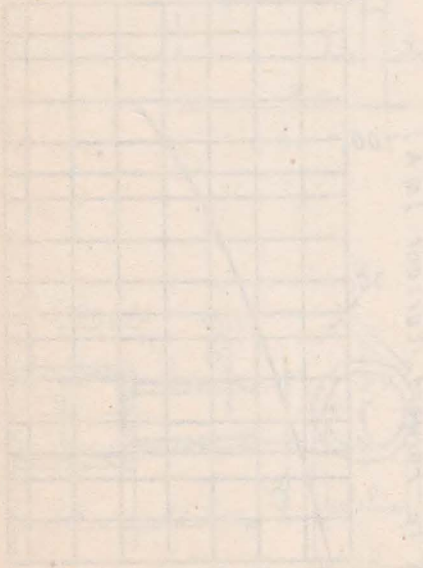

PHOTOTRANSISTOR

GENERAL DESCRIPTION

The MDR 4213 series are silicon npn phototransistors encapsulated in an epoxy case. The MDR 4213-11 has a standard $\varnothing 5$ mm epoxy case (fig. 1), the MDR 4213-51 has a rectangular case (fig. 2) and the MDR 4213-31 a miniature ($\varnothing 3$ mm) case (fig. 3).

FEATURES

- * White clear epoxy case
- * Suitable for visible and near infrared radiation
- * High sensitivity
- * Axial terminals

APPLICATIONS

- * Detector in electronic control and drive circuits
- * Detector in optocouplers

ABSOLUTE MAXIMUM RATINGS

$T_{amb} = 25^{\circ}\text{C}$

		STANDARD	MINIATURE	RECTANGULAR
Collector-Emitter Voltage	V	32	32	32
Maximum Collector Current	mA	50	50	50
Power Dissipation	Mw	200	100	200
Storage and Operating Temperature	$^{\circ}\text{C}$	-25...+70	-25...+70	-25...+70
Lead Soldering Temperature (soldering 3 sec.)	$^{\circ}\text{C}$	260	260 C	260

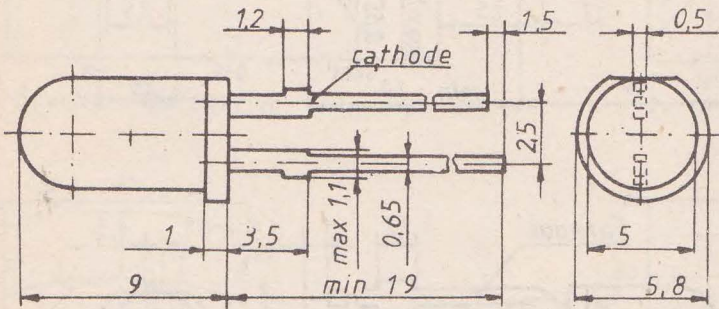

OPTOELECTRIC CHARACTERISTICS
 $T_{amb} = 25^{\circ}\text{C}$

Type	$V_{(BR)CEO}$ (V)	$I_C = 1\text{mA}$			λ^P	I_L (mA) $E_V = 1\text{klx}$ $V_{CE} = 10\text{V}$		I_D (nA) $E_V = 0$ $V_{CE} = 20\text{V}$		Case
		V_{CEsat} (V)	t_r (μs)	t_f (μs)		min.	max.	min.	max.	
MDR 4213-11A MDR 4213-11B MDR 4213-11C	32	0,3	10	10	830	0,2 1 2	100	standard $\varnothing = 5\text{mm}$ fig. 1		
MDR 4213-51A MDR 4213-51B	32	0,3	10	10	830	0,5 1,5	100	rectangular type, fig. 2		
MDR 4213-31A MDR 4213-31B	32	0,3	10	10	830	0,5 1,5	100	miniature $\varnothing = 3\text{mm}$, fig.3		

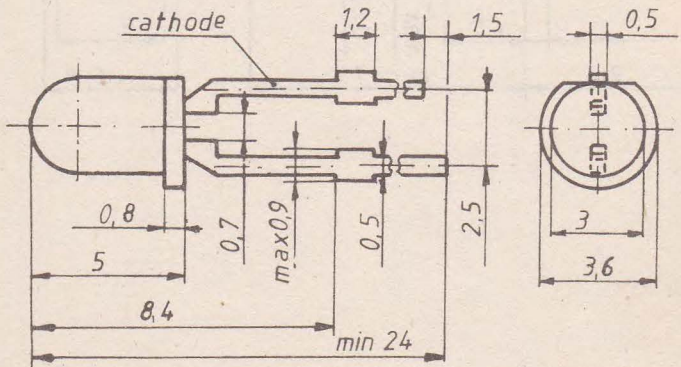
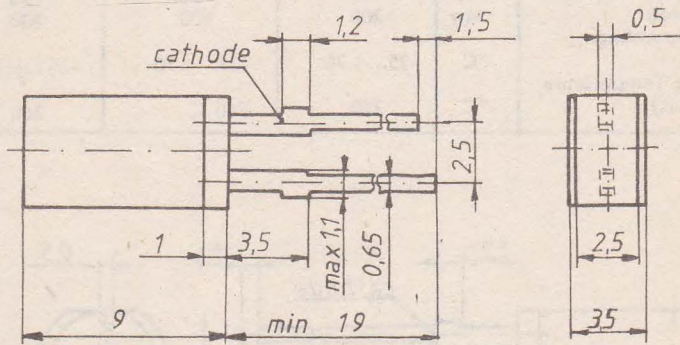

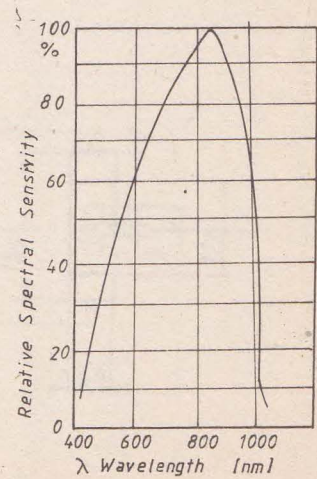
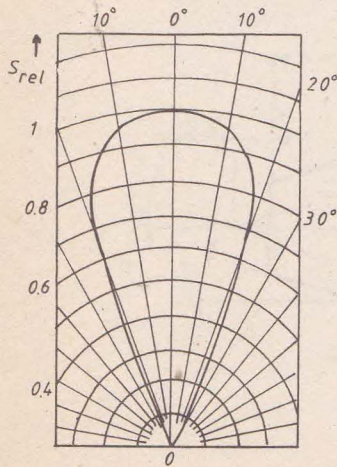
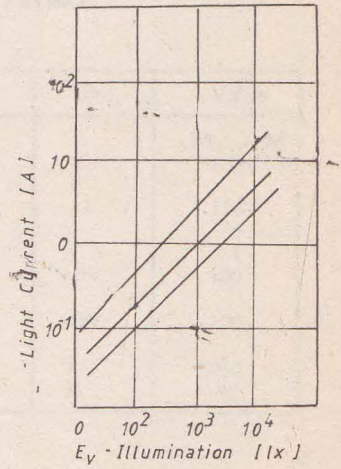
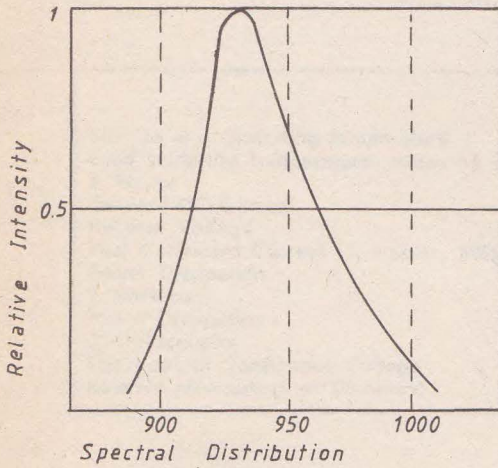
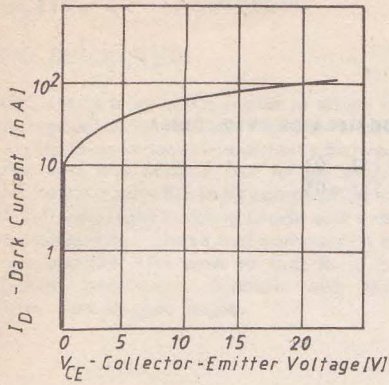

OPTOCOPLERS

REFLECTIVE OPTO-SWITCH

MDC 2211—01

GALVANIC ISOLATOR OPTO-COUPLER

MDC 1111—03

MDC 1111—05

REFLECTIVE OPTO-SWITCH

GENERAL DESCRIPTION

This MDC series is an optocoupler in which the optical coupling radiation is necessary to be reflected by an external reflective surface. The distance between the optocoupler and this surface has to be max. 5,6 mm. This MDC optocoupler has in its composition a rectangular MDE Infrared Light Emitting Diode and a rectangular MDR Phototransistor. These two compounds are mounted in an opaque ABS case so that their mechanical axes (which practically coincide with the optical axes) form a 34 degree angle.

FEATURES

- * Plastic case
- * Compact construction
- * Low coupling capacity

APPLICATIONS

- * Proximity photodetectors
- * Movement detectors
- * End of tape sensing

ABSOLUTE MAXIMUM RATINGS

$T_{amb} = 25^{\circ}\text{C}$

	Symbol	Unit.	Value
Storage and Operating temperature	$T_{op.}$	$^{\circ}\text{C}$	-25...+70
Lead soldering Temperature (soldering 3 sec)	$T_{slid.}$	$^{\circ}\text{C}$	+260
1. Emitter			
Forward DC Current	$I_F.$	mA	150
Reverse Voltage	$V_{R.}$	V	5
Peak Forward Current (1 μs pulse, 300pps)	$I_{FP.}$	A	1
Power Dissipation	$P_{tot.}$	mW	100
2. Receiver			
Power Dissipation	$P_{tot.}$	mW	100
3. Optocoupler			
Input-output Continuous Voltage	$V_{IO.}$	V	1000
Relative Moisture (t = 96 hours)		%	95

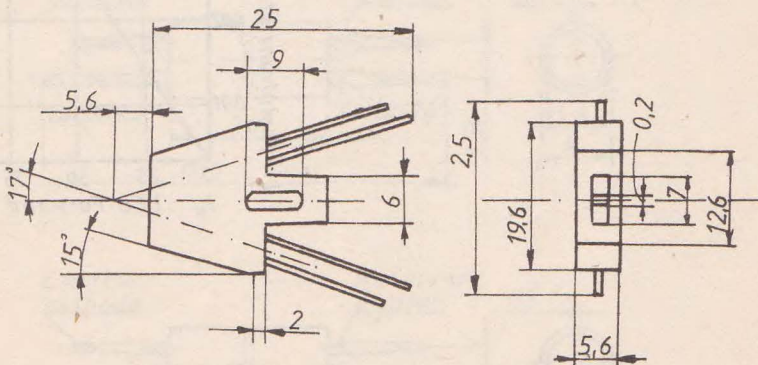

OPTOELECTRIC CHARACTERISTICS
 $T_{amb} = 25^{\circ}C$

CHARACTERISTIC	Symbol	Test condition.	Value		Unit.
			min.	max.	
1. Emitter Forward Voltage	V_F	$I_F = 100mA$		1,7	V
2. Receiver Collector-Emitter Breakdown Voltage	$V_{BR}(CEO)$	$I_C = 100\mu A$	30		V
Emitter-Collector Breakdown Voltage	$V_{BR}(ECO)$	$I_E = 100\mu A$			M
Collector-Emitter Leakage Current	I_{CEO}	$V_{CEO} = 10V$		0,5	μA
3. Optocoupler Collector Current	I_C	$I_F = 100mA$ $V_{CEO} = 10V$ $R = 0,5$ (reflection coef.)		0,05	mA
Rise Time	t_r	$R_L = 1k\Omega$		8	μs
Fall Time	t_f	$R_L = 1k\Omega$		8	μs

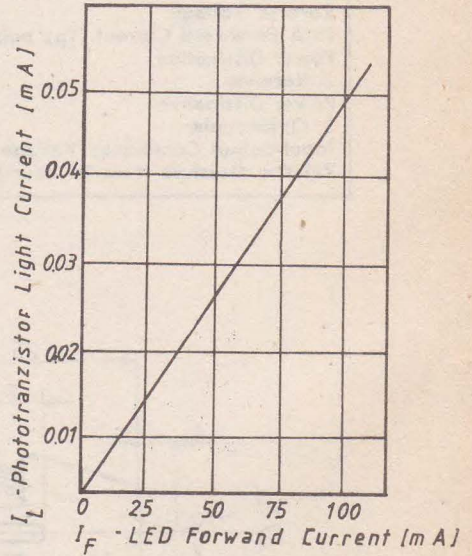
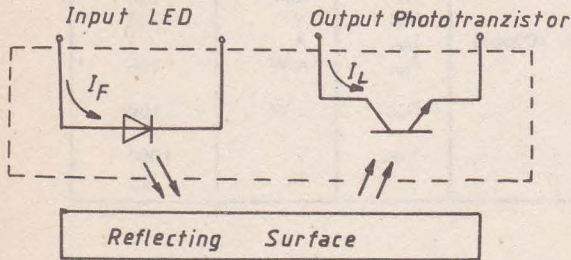

GALVANIC ISOLATOR OPTOCOUPLER

GENERAL DESCRIPTION

The MDE Galvanic Isolator Optocoupler consists of a MDE \varnothing 5 mm or \varnothing 3 mm Infrared LED and a MDE \varnothing 5 or \varnothing 3 mm Phototransistor. These two components are sealed in a \varnothing 5 or \varnothing 3 mm opaque plastic tube.

FEATURES

- * Hermetically plastic case
- * Low coupling capacity
- * DC isolation voltage
- * Compact construction

APPLICATIONS

- * Galvanically separated circuits

ABSOLUTE MAXIMUM RATINGS

$T_{amb} = 25^{\circ}\text{C}$

OPTOELECTRIC CHARACTERISTICS

	Symbol	UM	Value
Storage and operating Temperature	$T_{op.}$	$^{\circ}\text{C}$	-25...+70
Lead Soldering Temperature (soldering 3 sec.)	$T_{sld.}$	$^{\circ}\text{C}$	+260
1. Emitter			
Forward DC current	$I_F.$	mA	50
Reverse Voltage	$V_R.$	V	5
Power Dissipation	$P_{tot.}$	mW	150
2. Receiver			
Power Dissipation	$P_{tot.}$	mW	100
Collector Current	$I_C.$	mA	50
3. Optocoupler			
Input-output Continuous Voltage	$V_{IO.}$	V	5000
Coupling Capacitance	$C_o.$	pF	0,3

PACKAGE DIMENSIONS

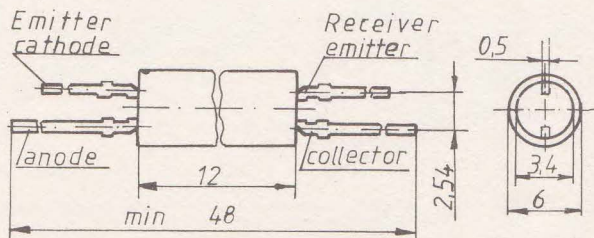
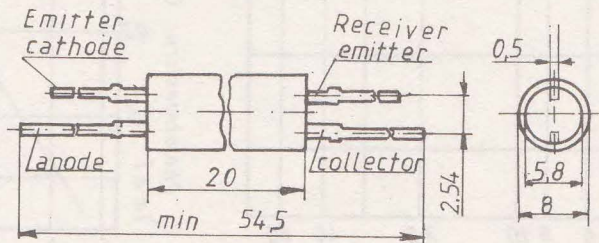

OPTOELECTRIC CHARACTERISTICS
 $T_{amb} = 25^{\circ}\text{C}$

Characteristic	Symbol	Test condition	Value		Unit.
			min.	max.	
1. Emitter Reverse Current	$I_{R\cdot}$	$V_R = 5\text{V}$		10	μA
Forward Voltage	$V_F\cdot$	$I_F = 50\text{mA}$		2	V
Breakdown Voltage	$V_{BR\cdot}$	$I_R = 100\mu\text{A}$	5		V
3. Receiver Collector-Emitter Breakdown Voltage	$V_{BR(CEO)\cdot}$	$I_C = 1\text{mA}$	32		V
Dark Current	$I_{D\cdot}$	$I_F = 0; E = 0$		100	nA
Saturation Voltage	$V_{CEsat}\cdot$	$V_{CE} = 20\text{V}$ $I_C = 1\text{mA}$ $E_V = 1\text{klx}$		0,3	V
3. Optocoupler Collector Current	$I_{C\cdot}$	$I_F = 50\text{mA}$ $V_{CEO} = 10\text{V}$	7	10	mA
Rise Time	$t_r\cdot$	$R_L = 1\text{k}\Omega$	10		μs
Fall Time	$t_f\cdot$	$R_L = 1\text{k}\Omega$	10		μs
Transfere factor	I_C / I_F		20		%
Max. frequency	$f_M\cdot$			100	kHz

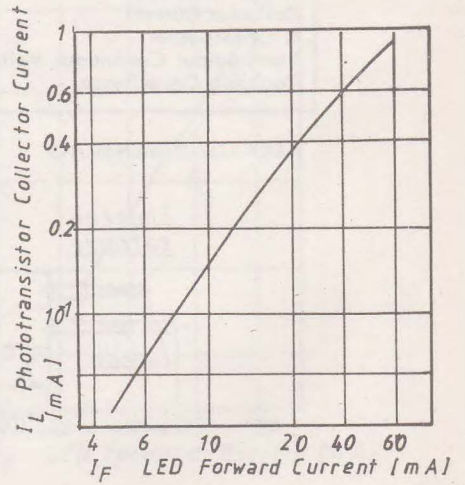
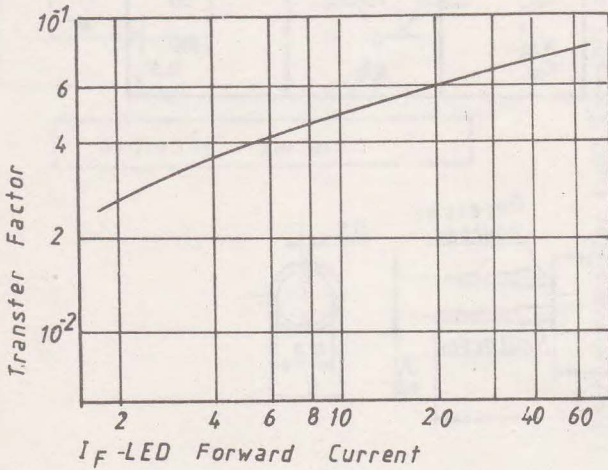

DISPLAYS

1 DIGIT

MDE 2101,2 R
 MDE 2101,2 V
 MDE 2111,2 R
 MDE 2111,2 V

OVERFLOW

MDE 2502-13,4 V
 MDE 2201,2 R
 MDE 2201,2 V
 MDE 2221,2 R
 MDE 2221,2 V

2 DIGITS

MDE 2502-01,2 R
 MDE 2502-01,2 V
 MDE 2502-03,4 R
 MDE 2502-03,4 V
 MDE 2502-11,2 R
 MDE 2502-11,2 V
 MDE 2502-13,4 R
 MDE 2583,4 R

1 1/2 DIGIT & SIGN

MDE 2541-01,2 R
 MDE 2541-01,2 V
 MDE 2541-03,4 R
 MDE 2541-03,4 V
 MDE 2551-11,2 R
 MDE 2551-11,2 V
 MDE 2551-13,4 R
 MDE 2551-13,4 V

3 1/2 DIGITS

MDE 2571,2 R
 MDE 2581,2 V

4 DIGITS

MDE 2573,4 R
 MDE 2573,4 V
 MDE 2583,4 V

9 DIGITS

MDE 2309-02 V
 MDE 2309-12 V

BARGRAPH

MDE 2954 RV

5x7 DOT MATRIX

MDE 2701,2 R
 MDE 2701,2 V

MDE 2101,2 R	AC	3	180 / 300	700	5
MDE 2111,2 R	CC	3	180 / 300	700	5
MDE 2101,2 V	AC	3	180 / 300	567	5
MDE 2111,2 V	CC	3	180 / 300	567	5

1 DIGIT DISPLAY

GENERAL DESCRIPTION

The 7,62 mm seven segment display with right hand, left hand or less decimal point and common anode or cathode are plastic encapsulated.

The emissive GaP-chips (LED) are mounted on a dual-in-line pin PCB.

FEATURES

- * High luminous intensity
- * Low power requirements
- * Wide viewing angle
- * High reliability and long life
- * Usable in vibrating environment

ABSOLUTE MAXIMUM RATINGS

$T_{amb} = 25^{\circ}C$

	Symbol	Unit.	Red	Green
Power, Dissipation (for segment or d.p.)	$P_{tot.}$	mW	50	80
Forward Current (for segment or d.p.)	$I_F.$	mA	20	20
Peak Forward current, (for segment or d.p.) (1 μ s pulse width, 300pps)	$I_{FP.}$	mA	60	60
Operating Temperature	$T_{op.}$	$^{\circ}C$	-25...+70	-25...+70
Storage Temperature	$T_{stg.}$	$^{\circ}C$	-40...+70	-25...+70
Lead Soldering Temperature ($t_{slid} = 3s$)	$T_{slid.}$	$^{\circ}C$	260	260

PACKAGE DIMENSIONS

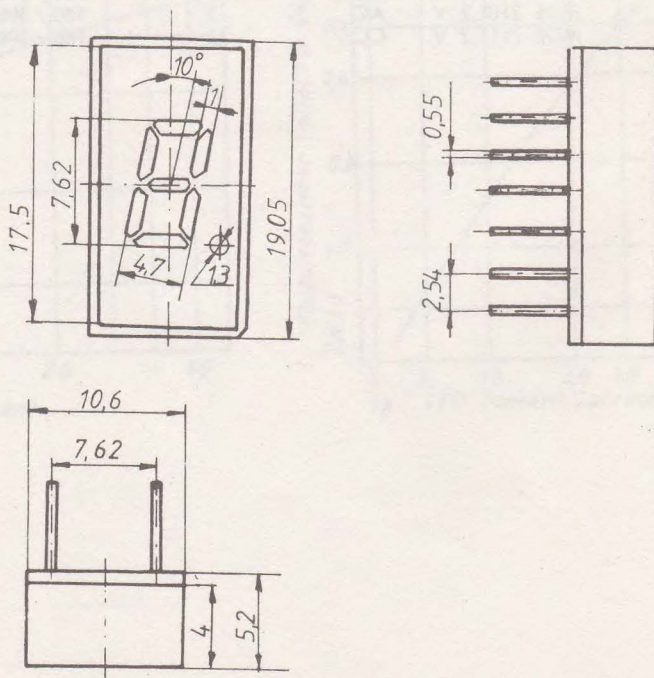

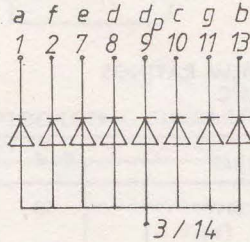
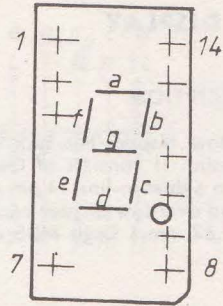
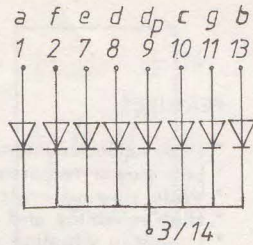

OPTOELECTRIC CHARACTERISTICS % SEGMENT OR DECIMAL POINT

Type	$T_{amb} = 25^{\circ}C, I_C = 10mA$		$I_R = 100\mu A$	
	$V_F(V)$ max.	$I_V(\mu cd)$ min.	$\lambda_P(nm)$ tip	$V_{BR}(V)$ min.
MDE 2101,2 R AC	3	180 / 300	700	5
MDE 2111,2 R CC	3	180 / 300	700	5
MDE 2101,2 V AC	3	180 / 300	567	5
MDE 2111,2 V CC	3	180 / 300	567	5

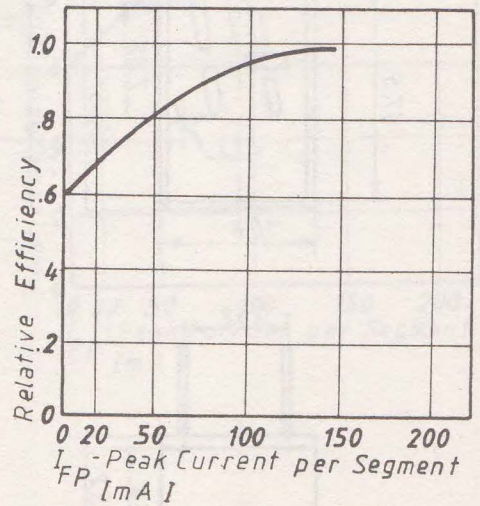
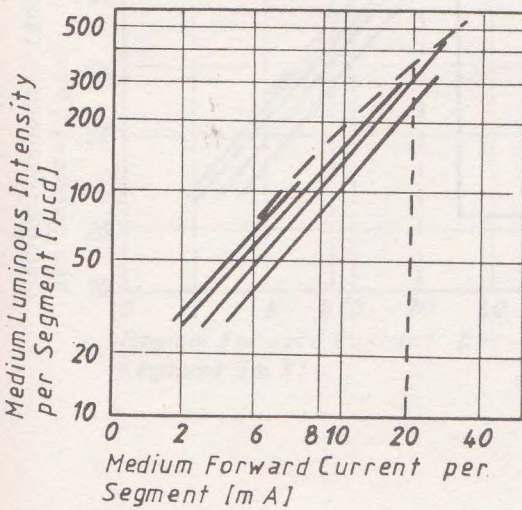

OVERFLOW DISPLAY

GENERAL DESCRIPTION

The MDE overflow display has four segments and a right decimal point. It consists of GaP red or green LEDs mounted on a dual-in-line 14 pin substrate. It provides polarity and overflow display capability. It is matched with the 7,62 mm 1 Digit MDE display.

FEATURES

- * High luminous intensity
- * Low power requirements
- * Wide viewing angle
- * High reliability and long life
- * Usable in vibrating environment.

ABSOLUTE MAXIMUM RATINGS

$T_{amb} = 25^{\circ}C$

	Symbol	Unit.	Red	Green
Power Dissipation (for segment or d.p.)	$P_{tot.}$	mW	50	80
Forward Current (for segment or d.p.)	$I_F.$	mA	20	20
Peak Forward Current (for segment or d.p.) (1 μ s pulse width, 300 pps)	$I_{FP.}$	mA	60	60
Storage Temperature	$T_{stg.}$	$^{\circ}C$	-40...+70	-40...+70
Lead Soldering Temperature ($t_{slid} = 3s$)	$T_{slid.}$	$^{\circ}C$	260	+260

PACKAGE DIMENSIONS

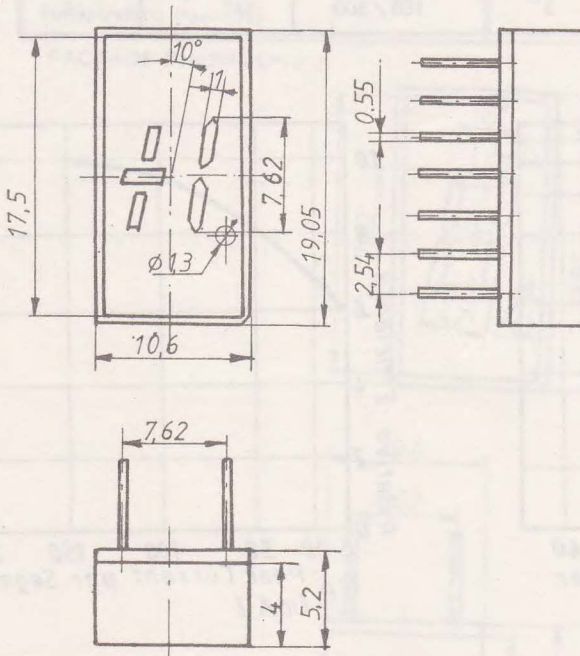

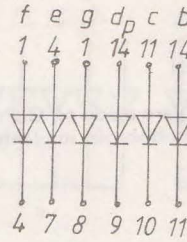
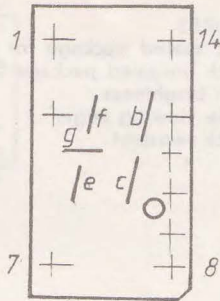

OPTOELECTRIC CHARACTERISTICS / SEGMENT OR DECIMAL POINT
 $T_{amb} = 25^{\circ}C$

TYPE	$I_F = 10mA$			$I_R = 100\mu A$
	$V_F(V)$	$I_V(\mu cd)$	$\lambda_P(nm)$	$V_{BR}(V)$
	max.	min.	tip	min.
MDE 2201,2 R	AC 3	180 / 300	700	5
MDE 2211,2 R	CC 3	180 / 300	700	5
MDE 2201,2 V	AC 3	180 / 300	567	5
MDE 2211,2 V	CC 3	180 / 300	567	5

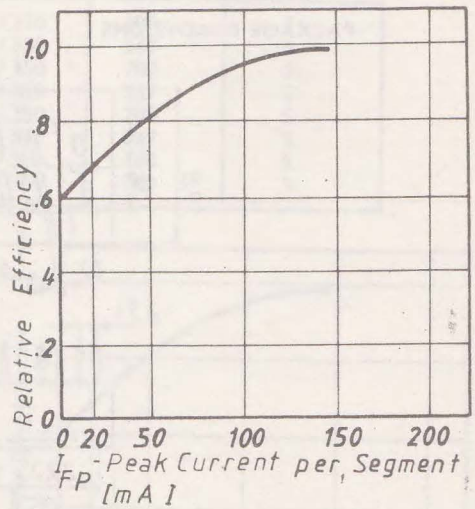
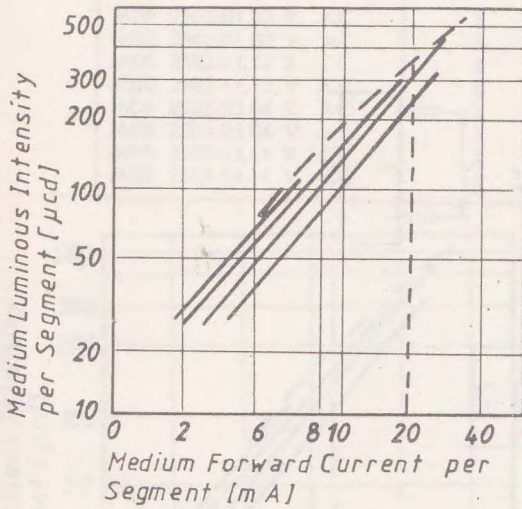

2 DIGITS

GENERAL DESCRIPTION

The emissive chips (LED) are made on GaP. These chips are mounted on a dual-in-line pin implanted PCB.

FEATURES

- * Back sealed package for MDE 2502-03, 04, 13, 14
- or back unsealed package for MDE 25-01, 02, 11, 12.
- * High brightness
- * Wide viewing angle
- * Shock resistant

ABSOLUTE MAXIMUM RATINGS

$T_{amb} = 25^{\circ}\text{C}$

	Symbol	Unit.	Red	Green
Power Dissipation (for segment or d.p.)	$P_{tot.}$	mW	50	80
Forward Current (for segment or d.p.)	I_F	mA	20	20
Peak Forward Current (for segment or d.p.) (1 μs pulse width, 300pps)	$I_{FP.}$	mA	60	60
Operating Temperature	$T_{op.}$	$^{\circ}\text{C}$	-40...+70	-25...+70
Storage Temperature	$T_{stg.}$	$^{\circ}\text{C}$	-40...+70	-40...+70
Lead Soldering Temperature ($t_{slid}=3\text{s}$)	$T_{slid.}$	$^{\circ}\text{C}$	260	260

PACKAGE DIMENSIONS

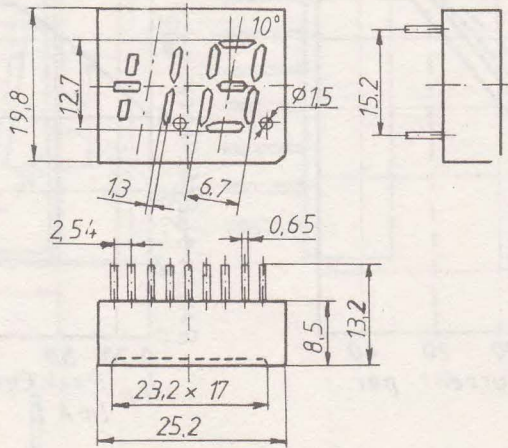

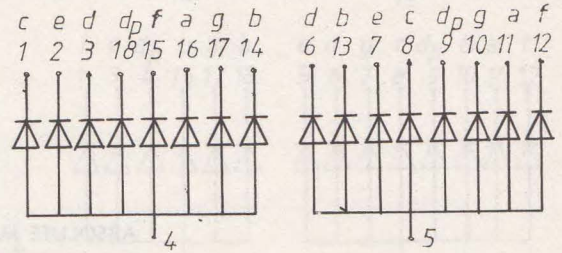
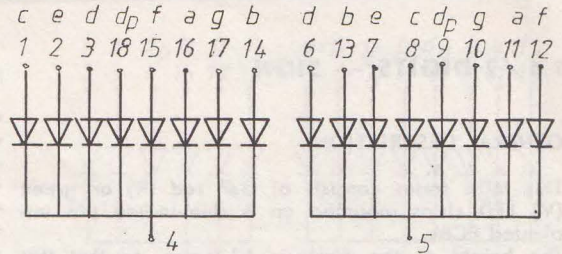
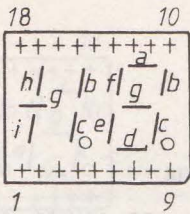

OPTOELECTRIC CHARACTERISTICS / SEGMENT OR DECIMAL POINT
 $T_{amb} = 25^{\circ}C$

TYPE	$I_f = 10mA$			$I_R = 100\mu A$
	$V_F(V)$	$I_V(\mu cd)$	$\lambda_P(nm)$	$V_{BR}(V)$
	max.	min.	tip.	min.
MDE 2502-01,02 R AC	3	230 / 350	700	5
MDE 2502-01,02 V AC	3	230 / 350	567	5
MDE 2502-11,12 R CC	3	230 / 350	700	5
MDE 2502-11,12 V CC	3	230 / 350	567	5
MDE 2502-03,04 R AC	3	230 / 350	700	5
MDE 2502-03,04 V AC	3	230 / 350	567	5
MDE 2502-13,14 R CC	3	230 / 350	700	5
MDE 2502-13,14 V CC	3	230 / 350	700	5

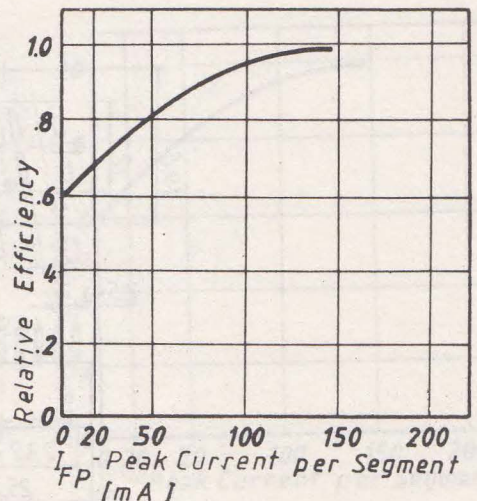
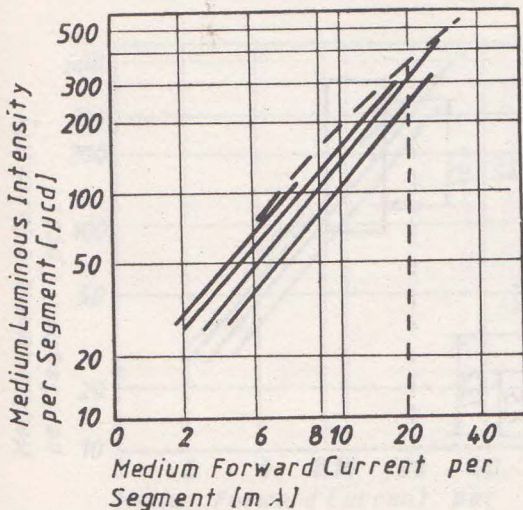

1 1/2 DIGITS — SIGN

FEATURES

GENERAL DESCRIPTION

This MDE series consists of GaP red (R) or green (V) LED chips mounted on a dual-in-line pin implanted PCBs.

The height of the digits is 12,7 mm, so that this display is matched with the '2 Digits' MDE series.

- * High luminous intensity
- * Low power requirements
- * Wide viewing angle
- * High reliability and long life
- * IC compatible
- * Back sealed package for MDE 2541-03, 2541-04, 2551-13, 2551-14 or back unsealed package for MDE 2541-01, 2541-02, 2551-11, 2551-12.

ABSOLUTE MAXIMUM RATINGS

$T_{amb} = 25^{\circ}\text{C}$

	Symbol	Unit.	Red	Green
Power Dissipation (for segment or d.p.)	$P_{tot.}$	mW	50	80
Forward Current (for segment or d.p.)	$I_F.$	mA	20	20
Peak Forward Current (for segment or d.p.) (1 μs pulse width, 300pps)	$I_{FP.}$	mA	60	60
Operating Temperature	$T_{op.}$	$^{\circ}\text{C}$	-25...+70	-25...+70
Storage temperature	$T_{stg.}$	$^{\circ}\text{C}$	-40...+70	-40...+70
Lead Soldering Temperature ($t_{slid}=3\text{s}$)	$T_{slid.}$	$^{\circ}\text{C}$	260	+260

PACKAGE DIMENSIONS

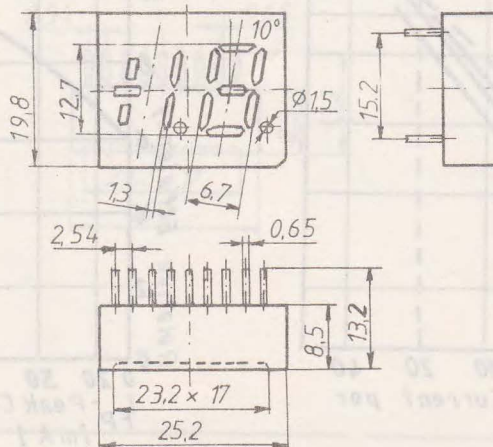

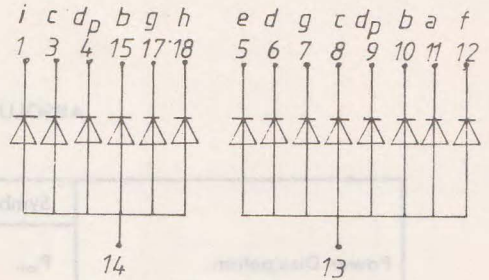
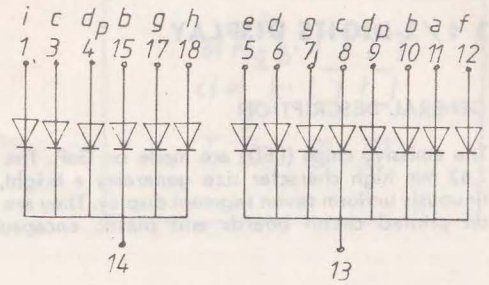
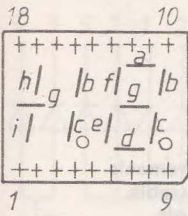

OPTOELECTRIC CHARACTERISTICS AT $T_{amb} = 25\text{ C}$

TYPE	$I_F = 20\text{mA}$		$I_R = 100\mu\text{A}$	
	$V_F(\text{V})$ max.	$I_V(\mu\text{cd})$ min.	$\lambda_P(\text{nm})$ tip.	$V_{BR}(\text{V})$ min
* MDE 2512-01,02 R AC	3	230 / 350	700	5
* MDE 2512-01,02 V AC	3	230 / 350	567	5
* MDE 2512-11,12 R CC	3	230 / 350	700	5
* MDE 2512-11,12 V CC	3	230 / 350	567	5

NOTES:

* - Product in development

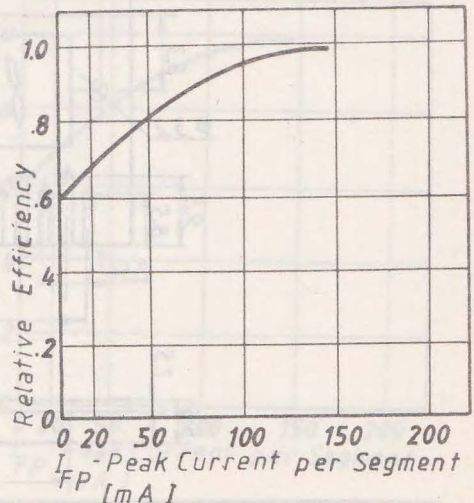
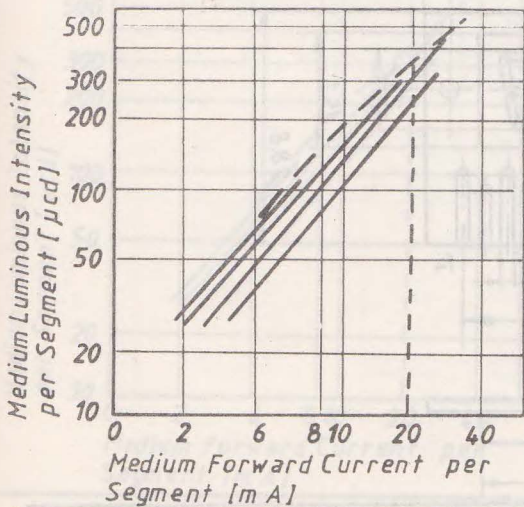

3 1/2 DIGITS DISPLAY

GENERAL DESCRIPTION

The emissive chips (LED) are made on GaP. The large 7,62 mm high character size generates a bright, continuously uniform seven segment display. They are made on printed circuit boards and plastic encapsulated.

FEATURES

- * High brightness
- * Low power requirements
- * Multiplexed addressable
- * Wide viewing angle
- * Shock resistant

APPLICATIONS

- * General indicating purposes
- * Time indication (clock, etc.)

ABSOLUTE MAXIMUM RATINGS

$T_{amb} = 25^{\circ}\text{C}$

	Symbol	Unit.	Red	Green
Power Dissipation (for segment or d.p.)	$P_{tot.}$	mW	50	80
Forward Current (for segment or d.p.)	$I_F.$	mA	20	20
Peak Forward Current (for segment or d.p.) (1 μs pulse width, 300pps)	$I_{FP.}$	mA	60	60
Operating Temperature	$T_{op.}$	$^{\circ}\text{C}$	-25...+70	-25...+70
Storage Temperature	$T_{stg.}$	$^{\circ}\text{C}$	-40...+70	-40...+70
Lead Soldering Temperature ($t_{slid.} = 3\text{s}$)	$T_{slid.}$	$^{\circ}\text{C}$	+260	+260

PACKAGE DIMENSIONS

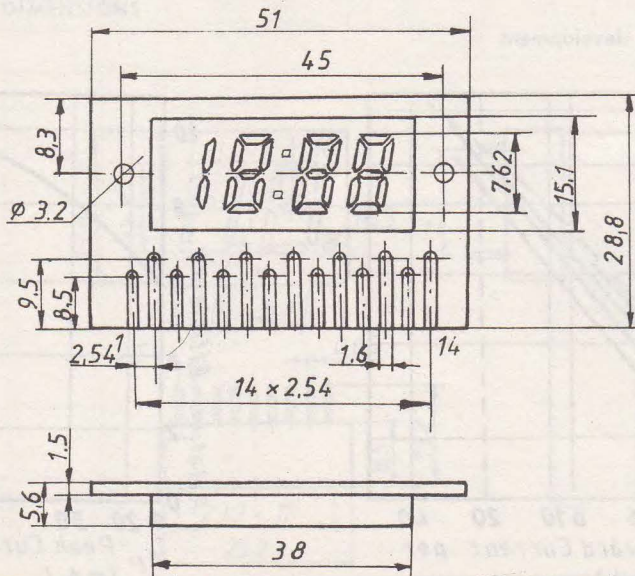

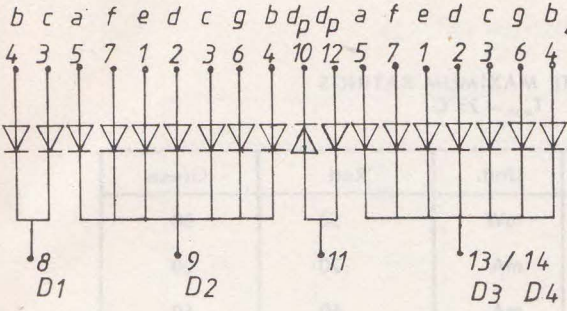
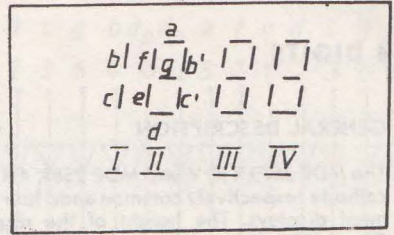
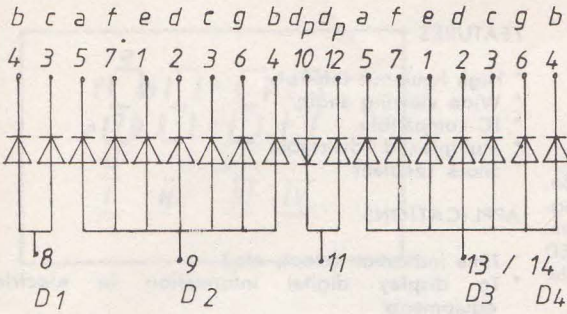

OPTOELECTRIC CHARACTERISTICS / SEGMENT OR DECIMAL POINT
 $T_{amb} = 25^{\circ}C$

TYPE	$I_F = 10mA$			$I_R = 100\mu A$
	$V_F(V)$ max.	$I_V(\mu cd)$ min.	$\lambda_p(nm)$ tip	$V_{BR}(V)$ min.
MDE 2571,2 R AC	3	180 / 300	700	5
MDE 2571,2 V AC	3	180 / 300	567	5
MDE 2581,2 R CC	3	180 / 300	700	5
MDE 2581,2 V CC	3	180 / 300	567	5

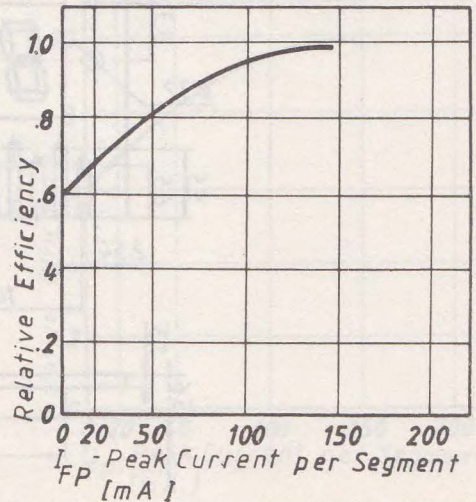
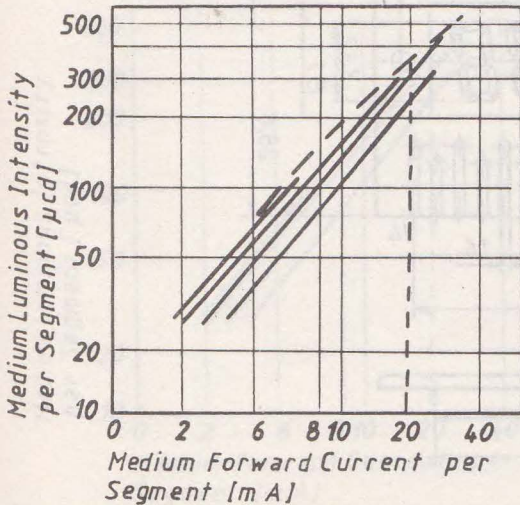

4 DIGITS

GENERAL DESCRIPTION

The MDE 2573,4 R, V and MDE 2583, 4 R, V are common, cathode respectively common anode four digit seven segment displays. The height of the digits is 7,62 mm. These MDE series are made of GaP red or green LED chips mounted on a printed circuit board and plastic encapsulated.

FEATURES

- * High luminous intensity
- * Wide viewing angle
- * IC compatible.
- * Multiplexed addressable
- * Shock resistant

APPLICATIONS

- * Time indication (clock, etc.)
- * To display digital information in electrical equipments

ABSOLUTE MAXIMUM RATINGS

$T_{amb} = 25^{\circ}C$

	Symbol	Unit.	Red	Green
Power Dissipation (for segment or d.p.)	$P_{tot.}$	mW	50	80
Forward Current (for segment or d.p.)	$I_F.$	mA	20	20
Peak forward Current (for segment or d.p.) (1 μ s pulse width, 300pps)	$I_{FP.}$	mA	60	60
Operating Temperature	$T_{op.}$	$^{\circ}C$	-25...+70	-25...+70
Storage Temperature	$T_{stg.}$	$^{\circ}C$	-40...+70	-40...+70
Lead Soldering Temperature ($t_{slid.} = 3s$)	$T_{slid.}$	$^{\circ}C$	+260	+260

PACKAGE DIMENSIONS

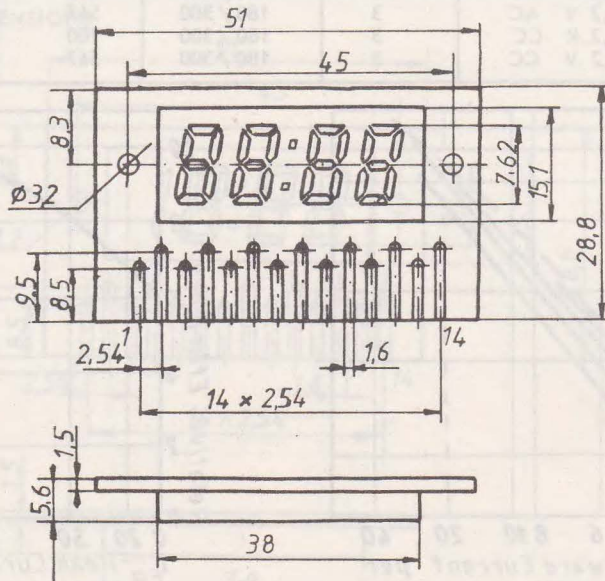

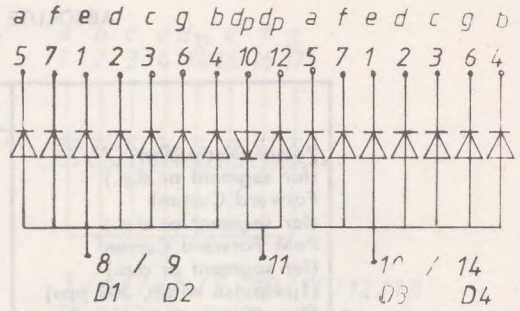
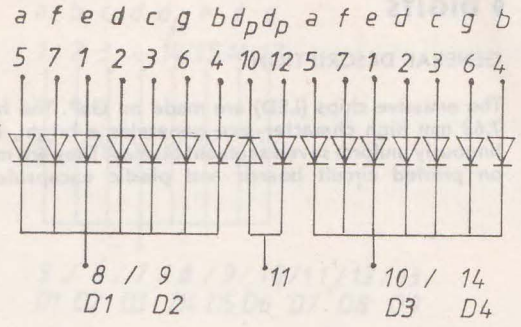
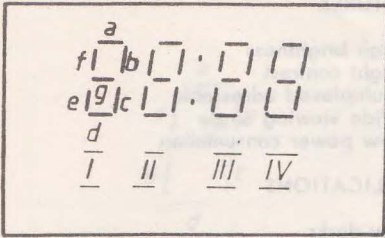

OPTOELECTRIC CHARACTERISTICS / SEGMENT OR DECIMAL POINT
 $T_{amb} = 25^{\circ}C$

TYPE	$I_F = 10mA$		$I_R = 100\mu A$	
	$V_F(V)$ max.	$I_V(\mu CD)$ min.	$\lambda_p(nm)$ tip.	$V_{BR}(V)$ min.
MDE 2573,4 R AC	3	180 / 300	700	5
MDE 2573,4 V AC	3	180 / 300	567	5
MDE 2583,4 R CC	3	180 / 300	700	5
MDE 2583,4 V CC	3	180 / 300	567	5

PACKAGE DIMENSIONS

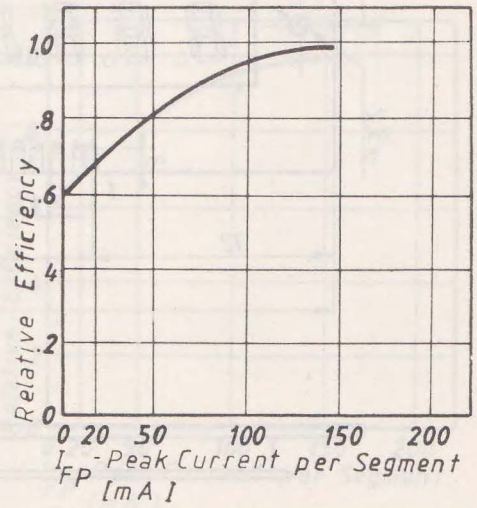
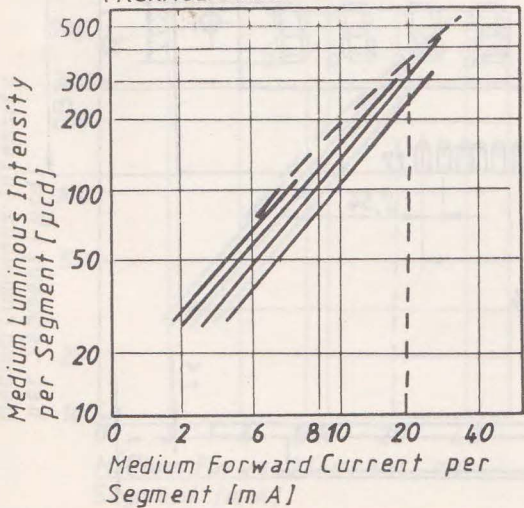

9 DIGITS

GENERAL DESCRIPTION

The emissive chips (LED) are made on GaP. The large 7,62 mm high character size generates a bright, continuously uniform seven segment display. They are made on printed circuit boards and plastic encapsulated.

FEATURES

- * High brightness
- * High contrast
- * Multiplexed addressable
- * Wide viewing angle
- * Low power consumption

APPLICATIONS

- * Pay-desks
- * Calculators
- * Digital readout displays

ABSOLUTE MAXIMUM RATINGS

$T_{amb} = 25^{\circ}\text{C}$

	Symbol	Unit.	Value
Power Dissipation (for segment or d.p.)	$P_{tot.}$	mW	80
Forward Current (for segment or d.p.)	$I_F.$	mA	20
Peak Forward Current (for segment or d.p.) (1 μs pulse width, 300 pps)	$I_{FP.}$	mA	60
Operating temperature	$T_{op.}$	$^{\circ}\text{C}$	-25...+70
Storage Temperature	$T_{stg.}$	$^{\circ}\text{C}$	-40...+70
Lead Soldering Temperature ($t_{sid.} = 3\text{s}$).	$T_{sid.}$	$^{\circ}\text{C}$	+260

PACKAGE DIMENSIONS

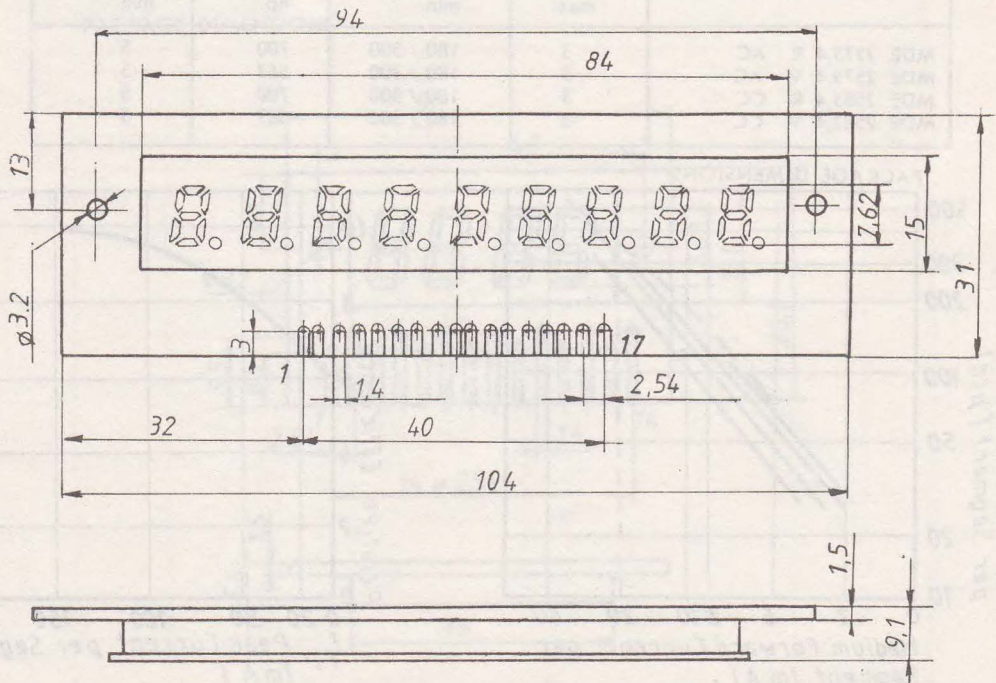

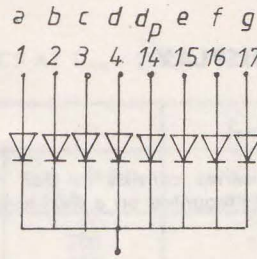
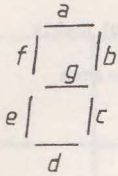

5 / 6 / 7 / 8 / 9 / 10 / 11 / 12 / 13
D1 D2 D3 D4 D5 D6 D7 D8 D9

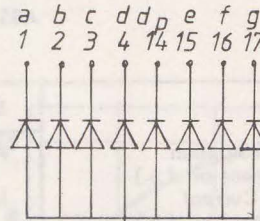

5 / 6 / 7 / 8 / 9 / 10 / 11 / 12 / 13
D1 D2 D3 D4 D5 D6 D7 D8 D9

OPTOELECTRIC CHARACTERISTICS / SEGMENT OR DECIMAL POINT
T_{amb} = 25°C

TYPE	V _F (V) max.	I _F = 10mA		I _R = 100μa
		I _V (μcd) min.	λ _P (nm) tip	V _{BR} (V) min.
MDE 2309-02 V AC	3	180	567	5
MDE 2309-12 V CC	3	180	567	5

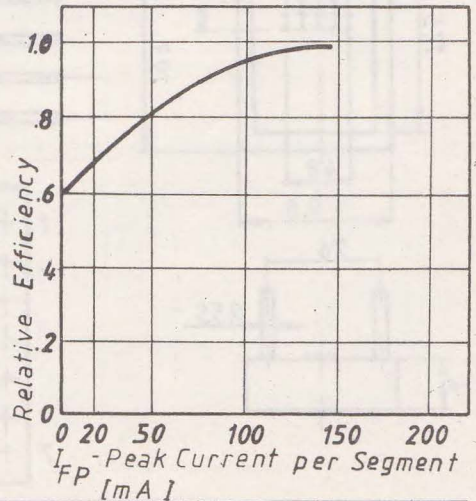
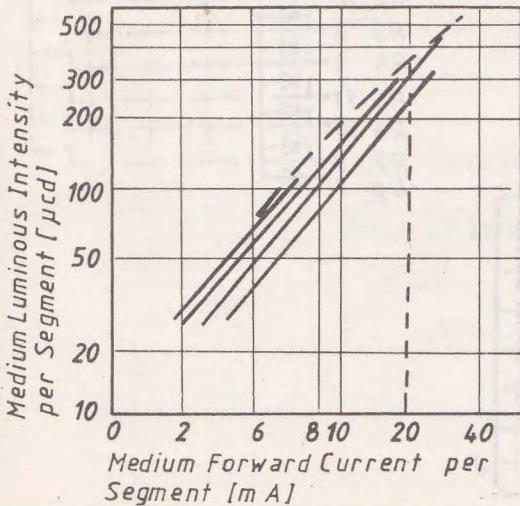

5X7 DOT MATRIX DISPLAY

GENERAL DESCRIPTION

The MDE 2701, 2 R, V series consists in GaP red (R) or green (V) LED chips mounted on a dual-in-line pin PCB.

FEATURES

- * 5x7 and decimal point dot matrix
- * Ideal for graphics panels
- * Excellent character appearance
- * Mechanically rugged

APPLICATIONS

- * Applications include electronic instrumentation, computer peripherals, point of sale terminals.

ABSOLUTE MAXIMUM RATINGS

$T_{amb} = 25^{\circ}C$

	Symbol	Unit.	Red	Green
Power Dissipation (for segment or d.p.)	$P_{tot.}$	mW	50	80
Forward Current (for segment or d.p.)	$I_F.$	mA	20	20
Peak Forward Current (for segment or d.p.) (1 μ s pulse width, 300pps)	$I_{FP.}$	mA	60	60
Operating Temperature	$T_{op.}$	$^{\circ}C$	-25...+70	-25...+70
Storage Temperature	$T_{stg.}$	$^{\circ}C$	-40...+70	-40...+70
Lead Soldering Temperature $T_{slid.} = 3s$	$T_{slid.}$	$^{\circ}C$	+260	+260

PACKAGE DIMENSIONS

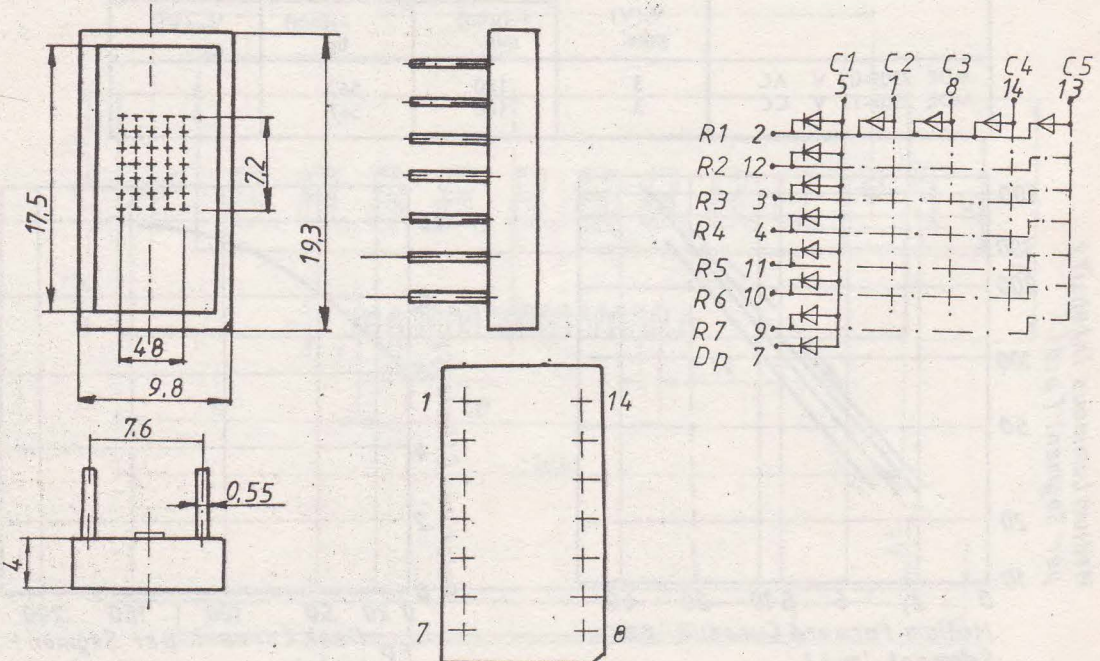

OPTOELECTRIC CHARACTERISTICS AT $T_{amb} = 25^{\circ}C$

TYPE	$V_F(V)$ max.	$I_F = 10mA$		$I_R = 100\mu A$
		$I_V(\mu cd)$ min.	$\lambda_P(nm)$ tip.	$V_{BR}(V)$ min.
* Red	3	150 / 250	700	5
* Green	3	150 / 350	567	5

NOTES :

- * Product in development

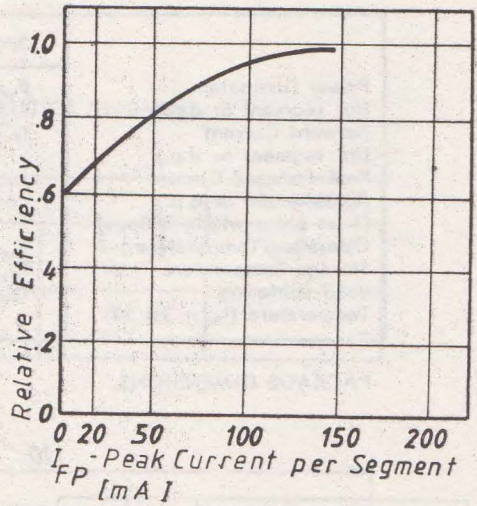
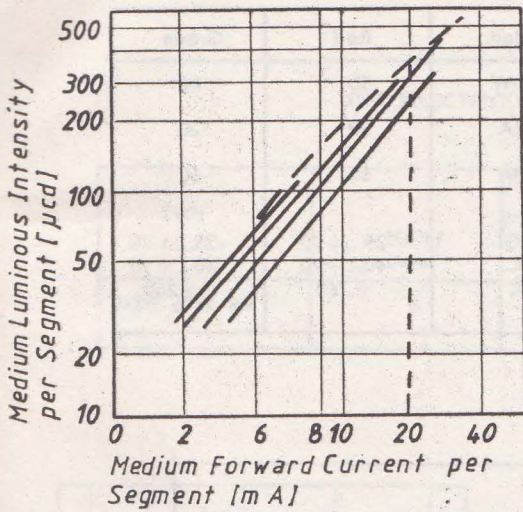

BARGRAPH

GENERAL DESCRIPTION

The MDE Bargraph has 2×11 segments: the first 2×7 segments are green and the rest are red.

The GaP red and green LED chips are mounted on a printed circuit board and plastic encapsulated.

FEATURES

- * High luminous intensity
- * Low power requirements
- * High reliability and long life

APPLICATIONS

- * Level meters
- * Audio, video electronic equipments

ABSOLUTE MAXIMUM RATINGS

 $T_{amb} = 5^{\circ}\text{C}$

	Symbol	Unit.	Red	Green
Power Dissipation (for segment or d.p.)	$P_{tot.}$	mW	50	80
Forward Current (for segment or d.p.)	$I_F.$	mA	20	20
Peak Forward Current (for segment or d.p.) (1 μs pulse width, 300pps)	$I_{FP.}$	mA	60	60
Operating Temperature	$T_{op.}$	$^{\circ}\text{C}$	-25...+70	-25...+70
Storage Temperature	$T_{stg.}$	$^{\circ}\text{C}$	-40...+70	-40...+70
Lead Soldering Temperature ($t_{sid.} = 3\text{s}$).	$T_{sid.}$	$^{\circ}\text{C}$	+260	+260

PACKAGE DIMENSIONS

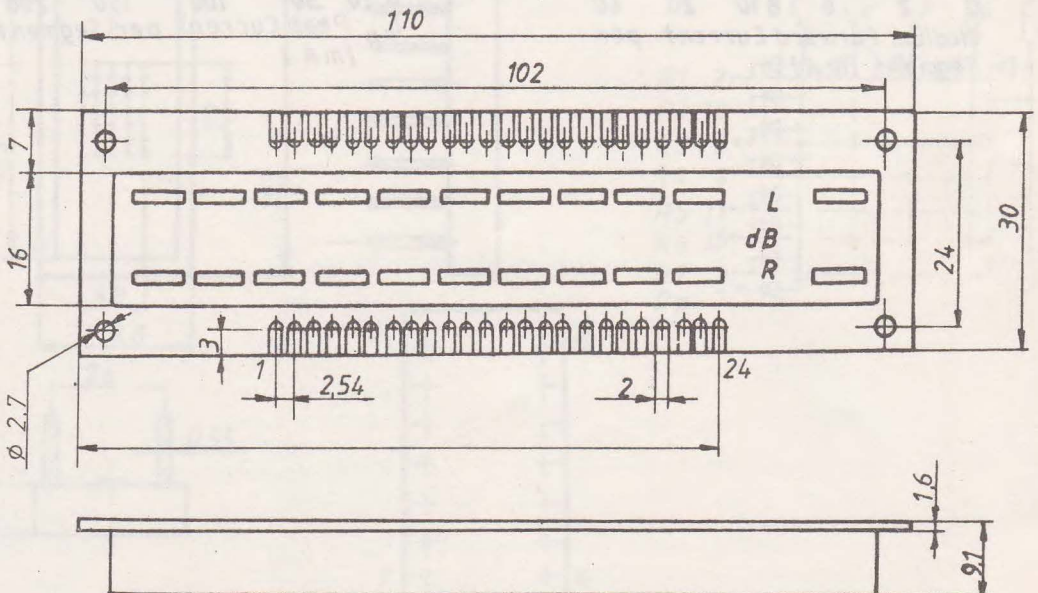

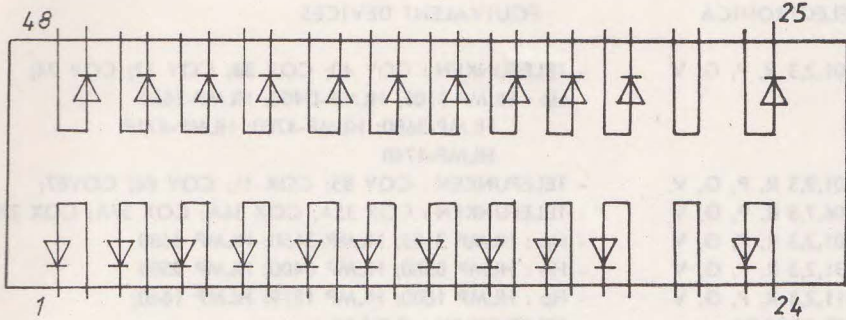

OPTOELECTRIC CHARACTERISTICS / SEGMENT
 $T_{amb} = 25^{\circ}C$

TYPE	$V_F(V)$ max.	$I_F = 10mA$		$I_R = 100\mu A$
		$I_V(\mu cd)$ min.	$\lambda_P(nm)$ tip	$V_{BR}(V)$ min.
MDE 2954 RV	3	100	700 567	5

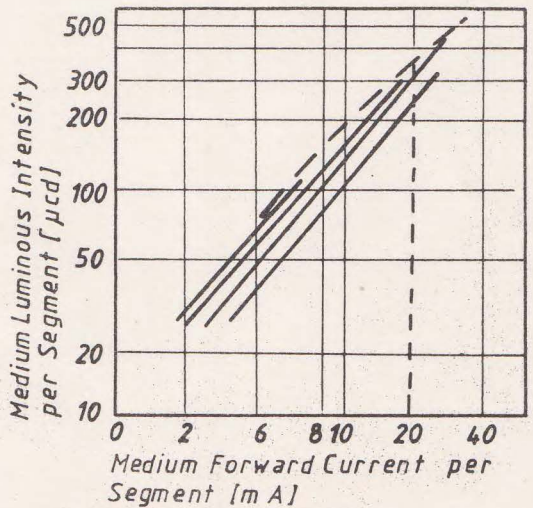
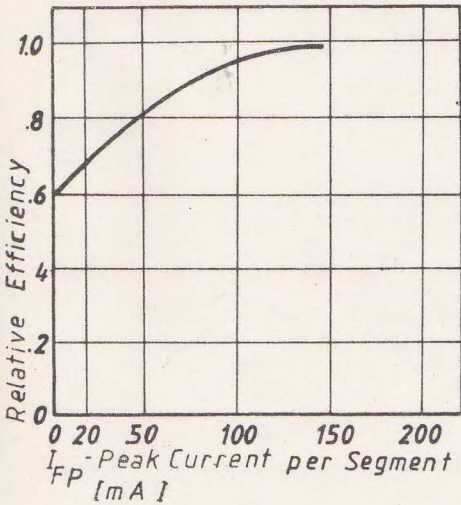

CROSS REFERENCE GUIDE

TYPE MICROELECTRONICA	EQUIVALENT DEVICES
MDE 1101,2,3 R, P, G, V	- TELEFUNKEN : CQY 40; CQX 38; CQY 72; CQY 74; - Hp : HLMP-3105; HLMP-D400; HLMP-3650 HLMP-3680; HLMP-4700; HLMP-4719 HLMP-4740
MDE 1301,2,3 R, P, G, V	- TELEFUNKEN : CQY 85; CQX 41; CQY 86; CQY87;
MDE 1106,7,8 R, P, G, V	- TELEFUNKEN : CQX 35A; CQX 36A; CQX 37A; CQX 39A;
MDE 1601,2,3 R, P, G, V	- Hp : HLMP 3105; HLMP 3650; HLMP 3680
MDE 1531,2,3 R, P, G, V	- Hp : HLMP 0300; HLMP 0400; HLMP 0503
MDE 1511,2,3 R, P, G, V	- Hp : HLMP 1800; HLMP 1819; HLMP 1840;
MDE 3123-02,05,06	- TELEFUNKEN : CQY 99
MDE 3323-16	- TELEFUNKEN : CQX 46
MDE 2101,2 R, V	- MBLÉ : CQY 81A, B;
MDE 2111,2 R, V	
MDE 2201,2 R, V	- SANYO : SL 1171 T; SL 1173 T;
MDE 2502-01,02,03,04 R, V	- RFT : VQE 21...24
MDE 2502-11,12,13,14 R, V	- SANYO : SL 2214 T
MDR 4213-11 A, B, C	- TELEFUNKEN : BPW 40;
MDR 4213-31 A,B	- TELEFUNKEN : BPW 42;
	- MBLÉ : BPW 22;
MDC 1111-03,05	- TELEFUNKEN : CNY-21;
	- MBLÉ : CNY-42;
MDC 2211-01	- HONEYWELL : HOA-1405

